



Pryda Timber Connectors

Post Anchor Guide

March 2017









**A complete guide to the design, specifications
and installation of Pryda Post Anchors**



Pryda Post Anchors Guide

TABLE OF CONTENTS

	<p>Post Anchors General installation information</p>	4
	<p>Design Capacities Summary</p>	5
	<p>Important notes</p> <p>Bushfire Attack Resistance BCA 2012 guideline</p>	6
	<p>Adjustable Post Anchor (PS) Convenient and fully adjustable for any practical post size. No checking of the post is required</p>	7
	<p>Bolt Down Post Anchor (PSB) With knockout 3 mm adjustable washer- to facilitate adjustment after bolt holes have been drilled. Used for locating posts onto existing concrete or decking.</p>	8
	<p>Centre Fix Post Anchor (PSCF) Generally used to “hide” the post anchor. The post is slotted at the bottom and bolted through the post and anchor, leaving only the bolt heads, nuts and washers visible. Can be bolted to existing concrete or decking or set into concrete</p>	9
	<p>Centre Pin Post Anchor (PSCP) For use where the post anchor is NOT to be visible. Due to the fixing method, it is only suitable for small spans or where no roofing is used</p>	10
	<p>Full Stirrup Post Anchor (PSF) Primarily used for bolting to existing concrete. Can also be used for setting to concrete</p>	11
	<p>Half Stirrup Post Anchor (PSH) Ideally suited to uses where the post is located against a wall or step and can only be bolted from one side. Can be bolted to existing concrete or decking or set into concrete</p>	12
	<p>High Wind Post Anchor (PSQ) Engineered for high wind areas, including tropical regions.</p>	13
	<p>Fixing to Concrete Pryda Post Anchors can be either embedded into concrete or fixed to the top surface of reinforced concrete slabs or bases using concrete anchors</p>	14

Product Information Updates

Information contained in this product guide is subject to change without notice. The latest updates are available from www.pryda.com.au.

POST ANCHORS

Economical Timber Post Anchors

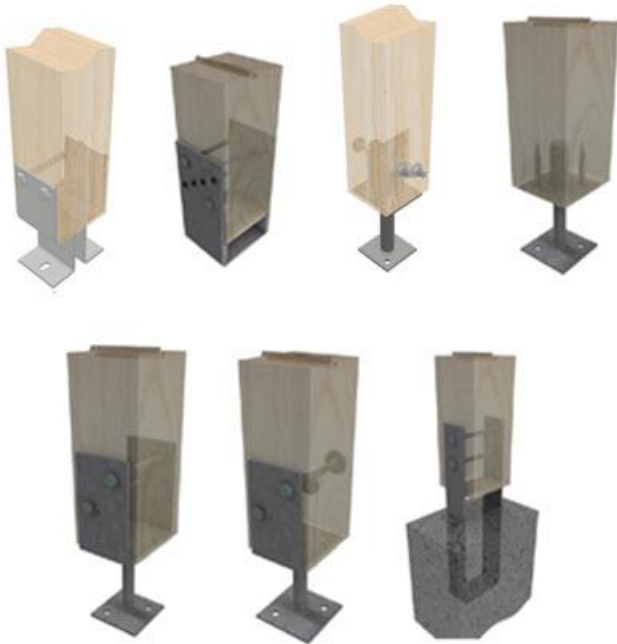

Advantages

Pryda Post Anchors are manufactured to a consistent quality. Advantages are:

- ▶ Compliance with building code requirements
- ▶ Hot dip galvanised coating after manufacture, to provide long term protection, suitable for severe external environments (as defined in the Building Code of Australia, HDG 300g/m²) which include sites within 1 km from the coast. (Excludes PSB anchors)
- ▶ Stems in stirrup anchors are sealed for termite protection
- ▶ Improved stability of the base with bolt holes close to the stem
- ▶ A large range of sizes to suit: (a) leg lengths from 65 mm to 600 mm (b) stirrup widths 90, 100, 115, 125 mm- and the Adjustable type to suit any post size (c) several configurations: Full Stirrup, Half Stirrup,

Bolt Down, Centre Fix, Centre Pin, High Wind and Adjustable.

Installation

Fixing requirements are included in the Design Capacities table on page 6. To install **Pryda Post Anchors**:

1. Adopt commercial bolts of strength grade 4.6 conforming to AS1111. Use 10 mm (or 3/8") diameter **galvanised bolts**, except for the High Wind type (PSQ) which requires 12 mm (or 1/2") diameter bolts. Where the bolt head or nut bears directly on the timber (Half Stirrup and Centre Fix types), a 45 mm diameter by 2.5 mm thick washer is required.
2. Use **galvanised coach screws**- 50x10 mm into side grain and 75x10 mm into end grain.
3. Anchors and bolts embedded in wet concrete must extend at least 56 mm into the concrete to develop the uplift loads tabulated in this guide.
4. The distance from the top of the concrete to the underside of the post anchor saddle must not exceed 300 mm.

Specification







The general specification for **Pryda Post Anchors** is:

Steel:	Grade 250 - AS1397 Hot dip galvanised
Sizes:	To suit all widths of timber posts. A variety of leg lengths – see in the following:
Application	Wet or dry concrete fixing.

The full range of these anchors is tabulated in Details following.

Design Capacities- Wind Uplift

Limit State Design capacities (ΦN_i) for Pryda Standard Post Anchors resisting wind uplift loads are as follows:

Post Anchor	Fixing	Post (mm)	Uplift Capacities for varying joint groups						
			J4	J3	J2	JD5	JD4	JD3	JD2
 Adjustable PS	4@ 50x10 mm coach screws	90 min.	4.6	7.4	9.2	5.8	8.4	11.9	12
 Bolt Down PSB	2@ M10 bolts	Any	Refer to Page 8						
 Centre Fix PSCF	2@ M10 bolts	90	9.1	11.5	12.0	11.5	12.0	12.0	12.0
 Centre Pin PSCP	2@ 75x10 mm coach screws	Any	4.1	6.0	8.2	3.9	5.2	7.5	10.3
 Full Stirrup PSFS	2@ M10 bolts		12.0	12.0	12.0	12.0	12.0	12.0	12.0
	4@ 50x10 mm coach screws	90	6.3	10.1	12.0	6.7	10.6	12.0	12.0
		100	6.1	9.6	12.0	6.5	10.3	12.0	12.0
		115	5.7	9.0	12.0	6.1	9.8	12.0	12.0
	125	5.3	8.5	11.7	5.9	9.3	12.0	12.0	
 Half Stirrup PSHS	2@ M10 bolts	Any	5.3	5.3	5.3	5.3	5.3	5.3	5.3
	2@ 50x10 mm coach screws		5.3	5.3	5.3	5.3	5.3	5.3	5.3
 High Wind PSQ	2@ M12 bolts	Any	33	41	45	36	41	50	

*Refer to notes on next page

Notes:

- 1 The design loads tabulated above require that: (a) the timber post must bear on the Post Anchor base and (b) all posts must be a minimum of 90x90 mm section.
- 2 Select design capacity according to the standard used for determining the design loads.
- 3 Specified capacities are for vertical load transfer only.
- 4 The base concrete and fixings to the concrete must provide sufficient resistance to the uplift forces and dead +live loads when embedding in to concrete.
- 5 Wind Uplift capacities are now based on the AS/NZS 1170:2002 code only, using $k1=1.14$.
- 6 Post Anchors should NOT be assumed to contribute towards lateral bracing/ raking stability of a structure in decks or stumps in sub-structure, unless pre-approved by an Engineer.
- 7 Post Anchors are not Intended to be used for cantilever posts and balustrades without pre-approval from an Engineer.

Bushfire Attack Resistance/ Termite Management

Most Pryda Post Anchors meet the requirements of the Building Code of Australia (NCC 2012), Volume 2. A minimum of 75 mm clearance between the underside of the Post Anchor saddle and the ground surface or paving level is recommended.

Complies with:

- AS 3660.1-2000 "Termite Management" Figure 5.5.

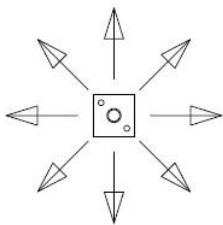

Recommend to slope foundation away from anchor base all around. Do not cover exposed base plate and stem with debris.

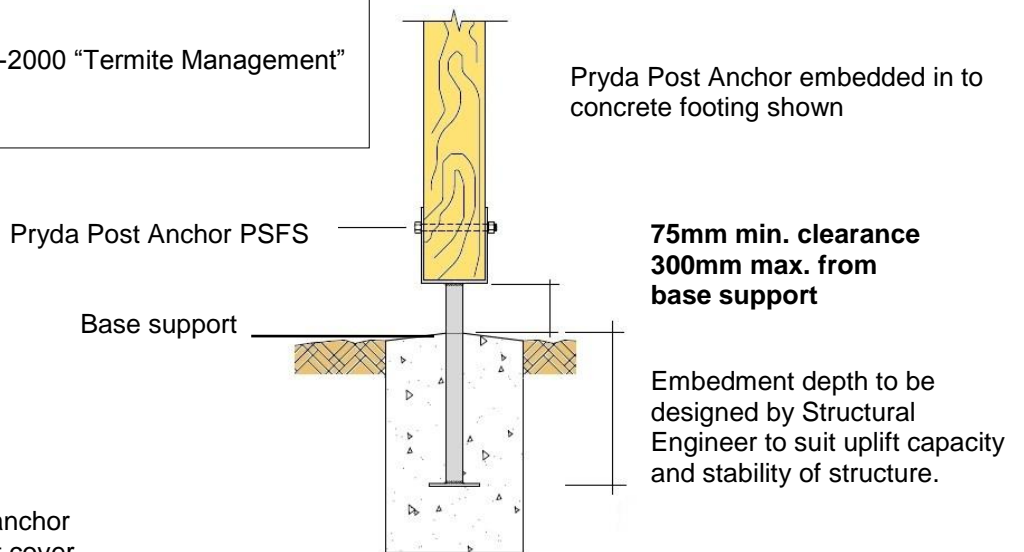

PSFS -Bolt down

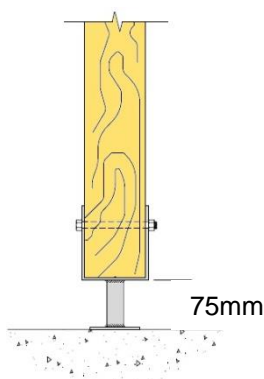

PSQ – High Wind

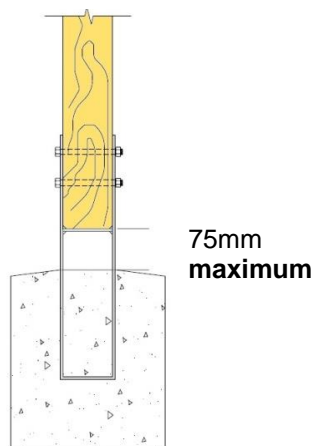

PSCF – Bolt down

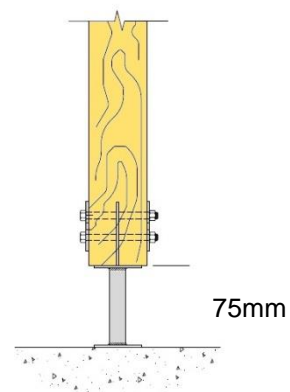

Adjustable Post Anchor

Convenient and fully adjustable for any practical post size. No checking of the post is required. Recommended post size 90mm-125mm or deem to be “fit for purpose” by end user. To be installed central to post.

Details

Pryda Post Anchors conform to AS3660.1 – 2000, Protection of Buildings from Termites. All joints are welded. Steel Grade 250 AS1397 -2001

Adjustable Post Anchors - Hot Dipped Galvanised 4 mm Steel

Product Code	Article & Size	Packed
PS85	85 Leg Length	10
PS160	160 Leg Length	10
PS200	200 Leg Length	10

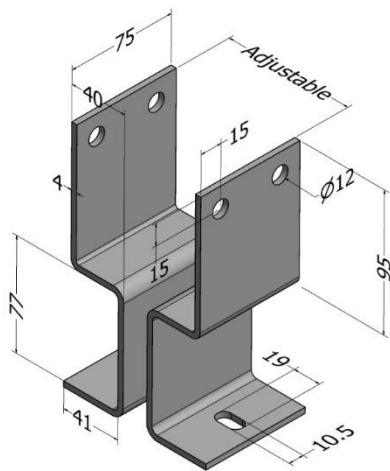

Adjustable Post Anchor



Design Capacities- Steel Strength only

Ultimate Limit State Design capacities (ΦN_c , ΦN_t) for **Pryda Standard Post**

Product Code	Axial Compression ΦN_c (kN)	Axial Tension ΦN_t (kN)
PS85	25	12
PS160	20	
PS200	16	

Design Capacities- Wind Uplift

Limit State Design capacities (ΦN_i) for **Pryda Standard Post Anchors** resisting wind uplift loads are as follows:

Post Anchor	Fixing	Post (mm)	Uplift Capacities for varying joint groups						
			J4	J3	J2	JD5	JD4	JD3	JD2
Adjustable PS	4@ 50x10 mm coach screws	90 min.	4.6	7.4	9.2	5.8	8.4	11.9	12

- Notes:
- The design loads tabulated above require that: (a) the timber post must bear on the Post Anchor base and (b) all posts must be a minimum of 90x90 mm section.
 - Select design capacity according to the standard used for determining the design loads.
 - Specified capacities are for vertical load transfer only.
 - The base concrete and fixings to the concrete must provide sufficient resistance to the uplift forces and dead +live loads when embedding in to concrete.
 - Wind Uplift capacities are now based on the AS/NZS 1170:2002 code only, using $k_1=1.14$.
 - Post Anchors should NOT be assumed to contribute towards lateral bracing/ raking stability of a structure in decks or stumps in sub-structure, unless pre-approved by an Engineer.
 - Post Anchors are not Intended to be used for cantilever posts and balustrades without pre-approval from an Engineer.

Bolt Down Post Anchor

With knockout 3 mm adjustable washer- to facilitate adjustment after bolt holes have been drilled. Used for locating posts onto existing concrete or decking. To be installed central to post.

Bolt Down Post Anchors – Galvabond & Hot Dipped Galvanised 2 mm Stirrup/ 3 mm Base

Product Code	Article & Size	Packed
PSB90G	H.D.G. for 90mm post	12
PSB100G	H.D.G. for 100mm post	12
PSB115G	H.D.G. for 115mm post	12
PSB125G	H.D.G. for 125mm post	12

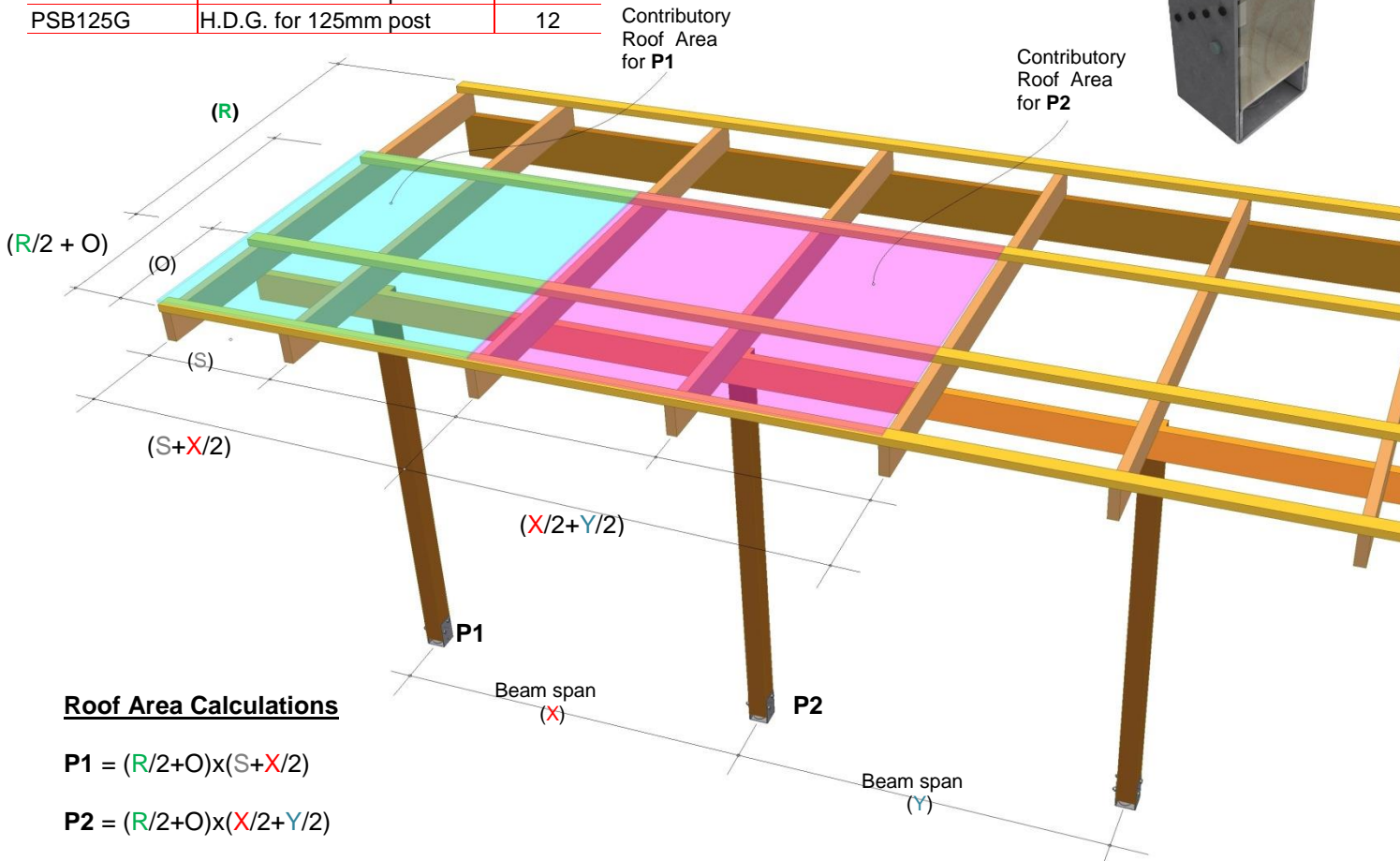
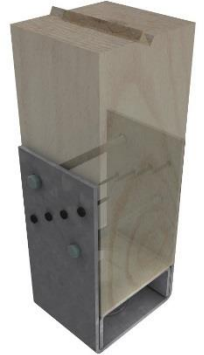

Roof Area Calculations

$$P1 = (R/2+O)x(S+X/2)$$

$$P2 = (R/2+O)x(X/2+Y/2)$$

Design Capacities- Wind Uplift

Limit State Design capacities (ΦN_i) for Pryda Standard Post Anchors resisting wind uplift loads are as follows:

Wind Speed	Sheet Roof (40kg/m ²)	Tile Roof (80kg/m ²)
	Maximum Roof Area m ²	
N2	5.8	9.9
N3	3.5	4.6
C1	2.4	3.0
C2	1.6	1.7

- Notes:
1. The design loads tabulated above require that: (a) the timber post must bear on the Post Anchor base and (b) all posts must be a minimum of 90x90 mm section.
 2. Select design capacity according to the standard used for determining the design loads.
 3. Specified capacities are for vertical load transfer only.
 4. The base concrete and fixings to the concrete must provide sufficient resistance to the uplift forces and dead +live loads when embedding in to concrete.
 5. Wind Uplift capacities are now based on the AS/NZS 1170:2002 code only, using $k_1=1.14$.
 6. Post Anchors should NOT be assumed to contribute towards lateral bracing/ raking stability of a structure in decks or stumps in sub-structure, unless pre-approved by an Engineer.
 7. Post Anchors are not Intended to be used for cantilever posts and balustrades without pre-approval from an Engineer.

Centre Fix Post Anchor

Generally used to “hide” the post anchor. The post is slotted at the bottom and bolted through the post and anchor, leaving only the bolt heads, nuts and washers visible. Can be bolted to existing concrete or set into concrete. To be installed central to post and selected post size deemed to be “fit for purpose” by end user.

Details

Pryda Post Anchors conform to AS3660.1 – 2000, Protection of Buildings from Termites. All joints are welded. Range dimensions are: Stem– 25 mm diameter x 2.0 mm thickness, Stirrup thickness = 4 mm. Steel Grade 250 AS1397 -2001

Centre Fix Post Anchors - Hot Dipped Galvanised 4 mm Steel

Product Code	Article & Size	Packed
PSCF130	130 Leg Length	10
PSCF300	300 Leg Length	10

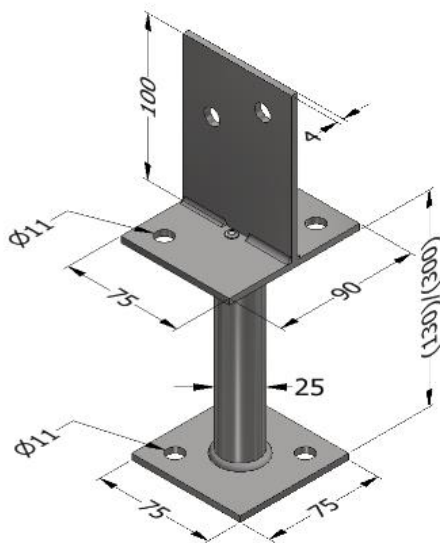

Centre Fix Post Anchor



Design Capacities- Wind Uplift

Limit State Design capacities (ΦN_i) for **Pryda Standard Post Anchors** resisting wind uplift loads are as follows:

Post Anchor	Fixing	Post (mm)	Uplift Capacities for varying joint groups						
			J4	J3	J2	JD5	JD4	JD3	JD2
Centre Fix PSCF	2@ M10 bolts	90	9.1	11.5	12.0	11.5	12.0	12.0	12.0

- Notes:
- 1 The design loads tabulated above require that: (a) the timber post must bear on the Post Anchor base and (b) all posts must be a minimum of 90x90 mm section.
 - 2 Select design capacity according to the standard used for determining the design loads.
 - 3 Specified capacities are for vertical load transfer only.
 - 4 The base concrete and fixings to the concrete must provide sufficient resistance to the uplift forces and dead +live loads when embedding in to concrete.
 - 5 Wind Uplift capacities are now based on the AS/NZS 1170:2002 code only, using $k_1=1.14$.
 - 6 Post Anchors should NOT be assumed to contribute towards lateral bracing/ raking stability of a structure in decks or stumps in sub-structure, unless pre-approved by an Engineer.
 - 7 Post Anchors are not Intended to be used for cantilever posts and balustrades without pre-approval from an Engineer.
 - 8 Design dead and live loads are likely to be limited by the capacity of the post, but should not exceed 16kN at the maximum stem height of 300mm and 25 kN for 130mm stem height or less.

Centre Pin Post Anchor

For use where the post anchor is NOT to be visible. Due to the fixing method, it is only suitable for small spans or where no roofing is used. To be installed central to post and selected post size deemed to be “fit for purpose” by end user.

Details

Pryda Post Anchors conform to AS3660.1 – 2000, Protection of Buildings from Termites. All joints are welded. Range dimensions are: Stem– 25 mm diameter x 2.0 mm thickness, Stirrup thickness = 4 mm. Steel Grade 250 AS1397 -2001

Centre Pin Post Anchors - Hot Dipped Galvanised 4 mm Steel

Product Code	Article & Size	Packed
PSCP130	130 Leg Length	10
PSCP300	300 Leg Length	10

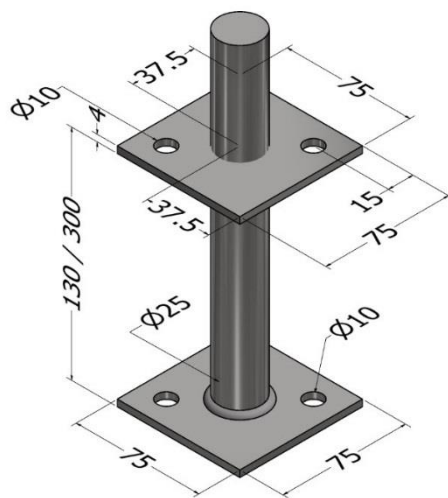

Centre Pin Post Anchor



Design Capacities- Wind Uplift

Limit State Design capacities (ΦN_i) for Pryda Standard Post Anchors resisting wind uplift loads are as follows:

Post Anchor	Fixing	Post (mm)	Uplift Capacities for varying joint groups						
			J4	J3	J2	JD5	JD4	JD3	JD2
Centre Pin PSCP	2 @ 75x10 mm coach screws	Any	4.1	6.0	8.2	3.9	5.2	7.5	10.3

- Notes:
- 1 The design loads tabulated above require that: (a) the timber post must bear on the Post Anchor base and (b) all posts must be a minimum of 90x90 mm section.
 - 2 Select design capacity according to the standard used for determining the design loads.
 - 3 Specified capacities are for vertical load transfer only.
 - 4 The base concrete and fixings to the concrete must provide sufficient resistance to the uplift forces and dead +live loads when embedding in to concrete.
 - 5 Wind Uplift capacities are now based on the AS/NZS 1170:2002 code only, using $k_1=1.14$.
 - 6 Post Anchors should NOT be assumed to contribute towards lateral bracing/ raking stability of a structure in decks or stumps in sub-structure, unless pre-approved by an Engineer.
 - 7 Post Anchors are not Intended to be used for cantilever posts and balustrades without pre-approval from an Engineer.
 - 8 Design dead and live loads are likely to be limited by the capacity of the post, but should not exceed 16kN at the maximum stem height of 300mm and 25 kN for 130mm stem height or less.

Full Stirrup Post Anchor (PSF)

Primarily used for bolting to existing concrete. Can also be used for setting to concrete having a maximum clearance. To be installed central to post.

Details

Pryda Post Anchors conform to AS3660.1 – 2000, Protection of Buildings from Termites. All joints are welded. Range dimensions are: Stem– 25 mm diameter x 2.0 mm thickness, Stirrup thickness = 4 mm.

Steel Grade 250 AS1397 -2001

Full Stirrup Post Anchors – Hot Dipped Galvanised 4 mm Steel

Product Code	Article & Size	Packed	Standard Product Code	Article & Size	Packed
PSFS6590	65mm leg for 90 mm post	10	PSFS30090	300mm leg for 90 mm post	10
PSFS65100	65mm leg for 100 mm post	10	PSFS300100	300mm leg for 100 mm post	10
PSFS13090	130mm leg for 90 mm post	10	PSFS300115	300mm leg for 115 mm post	10
PSFS130100	130mm leg for 100 mm post	10	PSFS300125	300mm leg for 125 mm post	10
PSFS130115	130mm leg for 115 mm post	10	PSFS37590	375mm leg for 90 mm post	10
PSFS130125	130mm leg for 125 mm post	10	PSFS45090	450mm leg for 90 mm post	10
PSFS20090	200mm leg for 90 mm post	10	PSFS450100	450mm leg for 100 mm post	10
PSFS200100	200mm leg for 100 mm post	10	PSFS450115	450mm leg for 115 mm post	10
PSFS25090	250mm leg for 90 mm post	10	PSFS450125	450mm leg for 125 mm post	10
PSFS250100	250mm leg for 100 mm post	10	PSFS60090	600mm leg for 90 mm post	10
			PSFS600100	600mm leg for 100 mm post	10

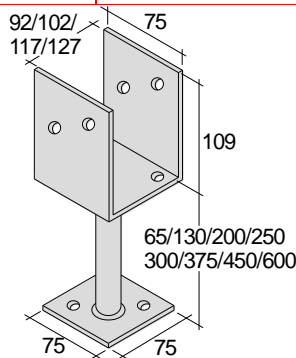

Full Stirrup Post Anchor (PSF)

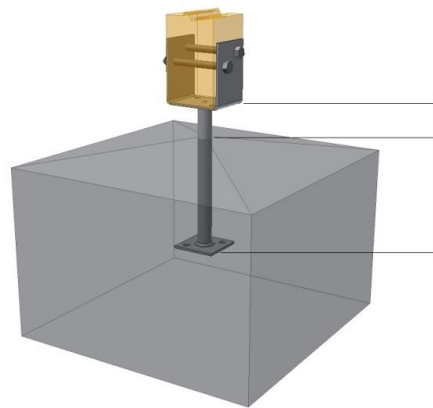

75mm min. Clearance
300mm max. from base support

Embedment depth to be designed by Structural Engineer for required Uplift capacity

Design Capacities- Wind Uplift

Limit State Design capacities (ΦN_i) for **Pryda Standard Post Anchors** resisting wind uplift loads are as follows:

Post Anchor	Fixing	Post (mm)	Uplift Capacities for varying joint groups						
			J4	J3	J2	JD5	JD4	JD3	JD2
Full Stirrup PSFS	2@ M10 bolts	90	12.0	12.0	12.0	12.0	12.0	12.0	12.0
		100	6.3	10.1	12.0	6.7	10.6	12.0	12.0
	4@ 50x10 mm coach screws	115	6.1	9.6	12.0	6.5	10.3	12.0	12.0
		125	5.7	9.0	12.0	6.1	9.8	12.0	12.0
		125	5.3	8.5	11.7	5.9	9.3	12.0	12.0

- Notes:
- The design loads tabulated above require that: (a) the timber post must bear on the Post Anchor base and (b) all posts must be a minimum of 90x90 mm section.
 - Select design capacity according to the standard used for determining the design loads.
 - Specified capacities are for vertical load transfer only.
 - The base concrete and fixings to the concrete must provide sufficient resistance to the uplift forces and dead +live loads when embedding in to concrete.
 - Wind Uplift capacities are now based on the AS/NZS 1170:2002 code only, using $k_1=1.14$.
 - Post Anchors should NOT be assumed to contribute towards lateral bracing/ raking stability of a structure in decks or stumps in sub-structure, unless pre-approved by an Engineer.
 - Post Anchors are not Intended to be used for cantilever posts and balustrades without pre-approval from an Engineer.
 - Design dead and live loads are likely to be limited by the capacity of the post, but should not exceed 16kN at the maximum stem height of 300mm and 25 kN for 130mm stem height or less.

Half Stirrup Post Anchor (PSH)

Ideally suited to uses where the post is located against a wall or step and can only be bolted from one side. Can be bolted to existing concrete or decking or set into concrete. Recommended maximum post size 90mm. To be installed central to post.

Details

Pryda Post Anchors conform to AS3660.1 – 2000, Protection of Buildings from Termites. All joints are welded. Range dimensions are: Stem– 25 mm diameter x 2.0 mm thickness, Stirrup thickness = 4 mm. Steel Grade 250 AS1397 -2001

Half Stirrup Post Anchors – Hot Dipped Galvanised 4 mm Steel

Product Code	Article & Size	Packed
PSHS65	65 Leg Length	10
PSHS130	130 Leg Length	10
PSHS200	200 Leg Length	10
PSHS300	300 Leg Length	10

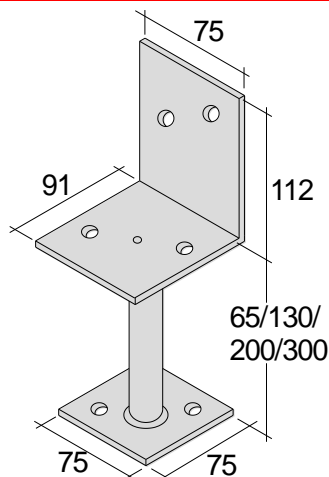

Half Stirrup Post Anchor (PSH)



Design Capacities- Wind Uplift

Limit State Design capacities (ΦN_i) for Pryda Standard Post Anchors resisting wind uplift loads are as follows:

Post Anchor	Fixing	Post (mm)	Uplift Capacities for 80kg/m ² Roof loading						
			J4	J3	J2	JD5	JD4	JD3	JD2
Half Stirrup PSHS	2@ M10 bolts	90	5.3	5.3	5.3	5.3	5.3	5.3	5.3
	2@ 50x10 mm coach screws		5.3	5.3	5.3	5.3	5.3	5.3	5.3

- Notes:
- The design loads tabulated above require that: (a) the timber post must bear on the Post Anchor base and (b) all posts must be a minimum of 90x90 mm section.
 - Select design capacity according to the standard used for determining the design loads.
 - Specified capacities are for vertical load transfer only.
 - The base concrete and fixings to the concrete must provide sufficient resistance to the uplift forces and dead +live loads when embedding in to concrete.
 - Wind Uplift capacities are now based on the AS/NZS 1170:2002 code only, using $k_1=1.14$.
 - Post Anchors should NOT be assumed to contribute towards lateral bracing/ raking stability of a structure in decks or stumps in sub-structure, unless pre-approved by an Engineer.
 - Post Anchors are not Intended to be used for cantilever posts and balustrades without pre-approval from an Engineer.
 - Design dead and live loads are likely to be limited by the capacity of the post, but should not exceed 16kN at the maximum stem height of 300mm and 25 kN for 130mm stem height or less.

High Wind Post Anchor

Engineered for high wind areas, including tropical regions.
The U shape base is designed for maximum hold-down in concrete.
See AS1684:2010 Part 3- Table 9.20 (j) reinforcing rod install over anchor end.
To be installed central to post.

Details

Pryda Post Anchors conform to AS3660.1 – 2000, Protection of Buildings from Termites. All joints are welded. Steel Grade 250 AS1397 -2001

High Wind Post Anchors - Hot Dipped Galvanised 5 mm Steel

Standard Product Code	Article & Size	Packed
PSQ30090/12	300 x 50 mm – 90 mm post	6
PSQ300100/12	300 x 50 mm- 100mm post	6
PSQ45090/12	450 x 50 mm- 90 mm post	6
PSQ450100/12	450 x 50 mm- 100mm post	6
PSQ60090/12	600 x 50 mm- 90 mm post	4
PSQ600100/12	600 x 50 mm- 100mm post	4
PSQ600125/12	600 x 50 mm- 125 mm post	4
PSQ600150/12	600 x 50 mm- 150 mm post	4

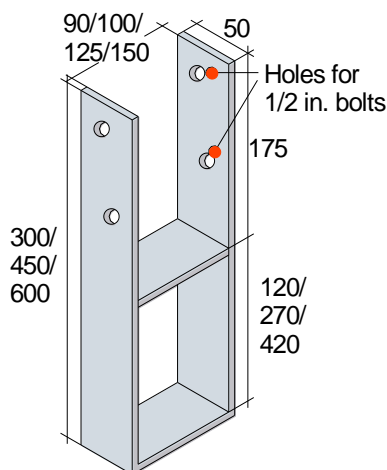

High Wind Post Anchor

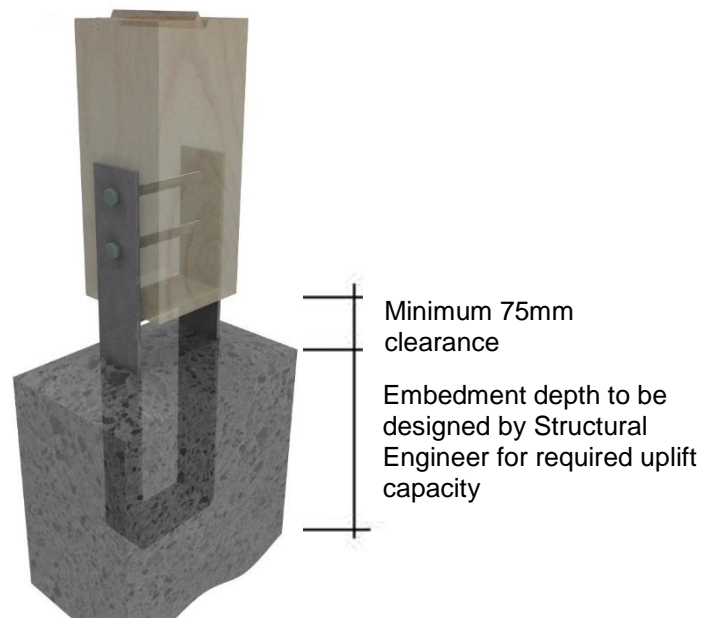

Design Capacities- Wind Uplift

Limit State Design capacities (ΦN_i) for Pryda Standard Post Anchors resisting wind uplift loads are as follows:

Post Anchor	Fixing	Post (mm)	Uplift Capacities for varying joint groups						
			J4	J3	J2	JD5	JD4	JD3	JD2
High Wind PSQ	2 @ M12 bolts	Any	33	41	45	36	41	50	50

- Notes:
- The design loads tabulated above require that: (a) the timber post must bear on the Post Anchor base and (b) all posts must be a minimum of 90x90 mm section.
 - Select design capacity according to the standard used for determining the design loads.
 - Specified capacities are for vertical load transfer only.
 - The base concrete and fixings to the concrete must provide sufficient resistance to the uplift forces and dead +live loads when embedding in to concrete.
 - Wind Uplift capacities are now based on the AS/NZS 1170:2002 code only, using $k_1=1.14$.
 - Post Anchors should NOT be assumed to contribute towards lateral bracing/ raking stability of a structure in decks or stumps in sub-structure, unless pre-approved by an Engineer.
 - Post Anchors are not Intended to be used for cantilever posts and balustrades without pre-approval from an Engineer.
 - High Wind Anchors (PSQ), the maximum downward loading is limited to 25kN at a height of 75mm from base of post to foundation.

Fixing to Concrete

Pryda Post Anchors can be either embedded into concrete or fixed to the top surface of reinforced concrete slabs or bases using concrete anchors.

For this purpose, Pryda recommends M10 Hex Head Ramset™ AnkaScrews™, code AS10060H (available from Pryda) or AS10075H, which have properties as follows:

AnkaScrew Code	AS10060H	AS10075H
Diameter (mm)	10	10
Effective depth (mm)	56	71
Concrete depth min. (mm)	75	100
Concrete capacity (MPa)	20	20
Edge distance min. (mm)	40	40
Spacing (min.) (mm)	60	60
Design Capacity (kN) – two anchors	18.5	25.8

For other use conditions, the above design capacity must be adjusted by the following factors:

Concrete Strength (MPa)	20	25	32	40
Factor	1.0	1.08	1.18	1.27
Edge distance (mm)	Less than 30	30	35	40 or more
Factor	NS	0.83	0.91	1.0

Note: NS means not suitable.

Installation of AnkaScrews is quick and easy. They are self-tapping and non-expansive. See the Ramset installation instructions on their web site: www.ramset.com.au or contact Ramset.

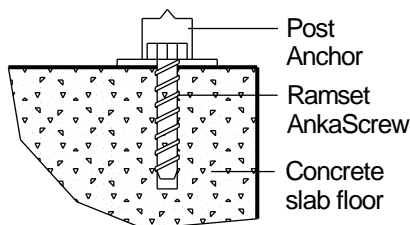

Post Anchor Fixing to Concrete Slab Detail

Pryda Australia | A Division of ITW Australia Pty Ltd

153-187 Discovery Road, Dandenong South, Vic 3175
Offices in Melbourne, Sydney, Brisbane.
Representatives in all States.

Website: www.pryda.com.au
Email: info@prydaanz.com
Tel: 1800 810 741