

Design Guide

Narrow Wall Bracing Units

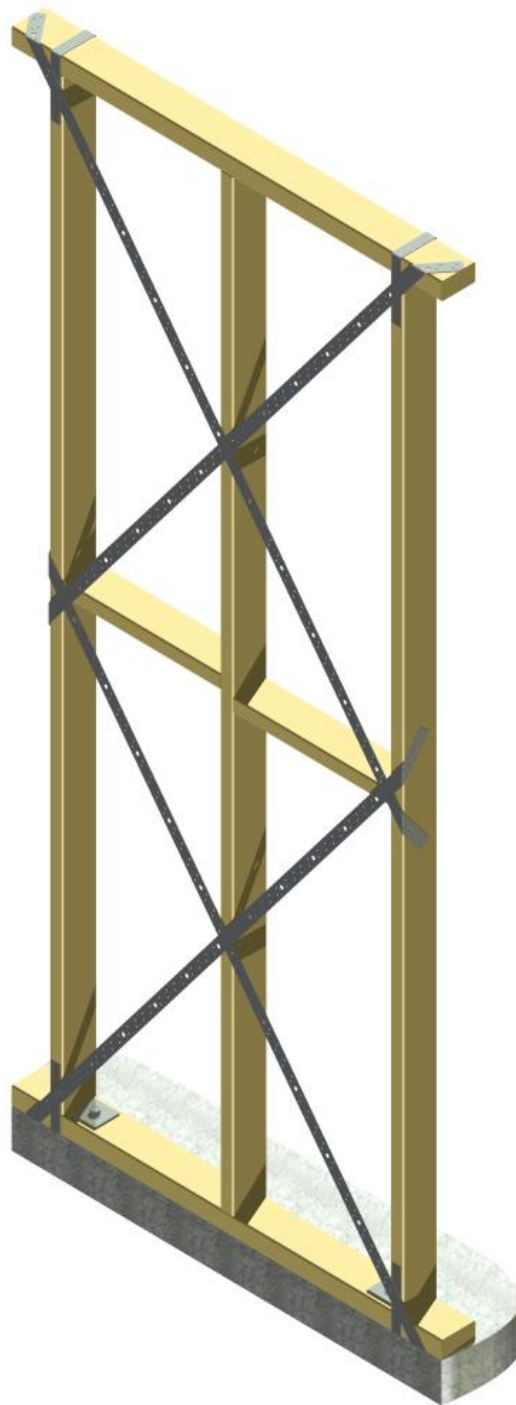

Copyright: (c) Pryda Australia
A Division of ITW Australia

DESIGN GUIDE for NARROW WALL BRACING UNITS

Procedure

1. For the wall height and width, select the type of bracing panel you want from one of three types:

Type SW1 - Single Pryda Strapbrace (SB103 – 30x1.0) for low bracing capacities

Type SW2 - Single Pryda Speedbrace (SDB) or Strapbrace (SB123 – 32x1.2) for normal bracing capacities.

Type SW3 - Double Pryda Speedbrace (2/SDB) or Strapbrace (2/SB123) for high bracing capacities

Note: SB083 may be used in lieu of SB103 for Type SW1 bracing units provided the capacities are reduced by 20%.

Note: Refer to **Pryda Wall Truss Brace** design guide for an alternative solution to narrow wall bracing units

2. From the chosen wall height, width and brace type, obtain the bracing capacity from the tables below.

Notes:

- I. The reduced capacity between 1400 mm and 1500 mm wide walls is due to the change in brace configuration.
- II. The design capacities include the contribution from plasterboard cladding fixed on one face for external walls and both faces for internal walls.
- III. For Unit Widths of 1800mm and above, refer Pryda Bracing Guide or AS1684 for design capacities.

The wall height is nominal, so the details for 2400mm can be used for wall heights 2200–2500, and 2700mm for 2501–2800, and 3000mm for 2801 – 3100.

EXTERNAL WALLS

Wall Height 2400 mm (2200- 2500)

Brace Type	Bracing capacity (kN) for Unit Width (mm) of:											
	600	700	800	900	1000	1100	1200	1300	1400	1500	1600	1700
SW1	1.6	2.0	2.5	2.8	3.3	3.7	4.0	4.1	4.3	3.3	3.6	3.9
SW2	1.9	2.5	3.0	3.4	4.1	4.5	4.9	5.1	5.4	4.2	4.5	4.9
SW3	2.6	3.3	4.1	4.8	5.8	6.5	6.9	7.4	8.0	6.7	7.6	8.1

Wall Height 2700 mm (2501- 2800)

Brace Type	Bracing capacity (kN) for Unit Width (mm) of:											
	600	700	800	900	1000	1100	1200	1300	1400	1500	1600	1700
SW1	1.4	1.7	2.2	2.5	2.9	3.3	3.6	3.9	4.1	2.9	3.2	3.5
SW2	1.6	2.1	2.6	3.0	3.6	4.1	4.4	4.7	5.1	3.7	4.1	4.4
SW3	2.2	2.9	3.5	4.1	5.1	5.6	6.2	6.9	7.4	6.1	6.4	7.1

Wall Height 3000 mm (2801- 3100)

Brace Type	Bracing capacity (kN) for Unit Width (mm) of:											
	600	700	800	900	1000	1100	1200	1300	1400	1500	1600	1700
SW1	1.1	1.5	1.8	2.2	2.4	2.8	3.0	3.3	3.5	2.5	2.8	3.0
SW2	1.4	1.8	2.2	2.7	3.1	3.6	3.9	4.3	4.5	3.2	3.5	3.8
SW3	1.9	2.5	3.1	3.6	4.4	5.0	5.4	6.2	6.5	5.0	5.6	6.1

INTERNAL WALLS

Wall Height 2400 mm (2200- 2500)

Brace Type	Bracing capacity (kN) for Unit Width (mm) of:											
	600	700	800	900	1000	1100	1200	1300	1400	1500	1600	1700
SW1	1.8	2.2	2.7	3.1	3.7	4.0	4.3	4.5	4.7	3.8	4.1	4.4
SW2	2.1	2.7	3.2	3.7	4.4	4.8	5.3	5.5	5.8	4.7	5.0	5.4
SW3	2.8	3.5	4.3	5.1	6.1	6.8	7.3	7.8	8.4	7.1	8.0	8.6

Wall Height 2700 mm (2501- 2800)

Brace Type	Bracing capacity (kN) for Unit Width (mm) of:											
	600	700	800	900	1000	1100	1200	1300	1400	1500	1600	1700
SW1	1.6	1.9	2.4	2.8	3.3	3.7	4.0	4.2	4.5	3.4	3.7	4.0
SW2	1.8	2.3	2.8	3.3	3.9	4.4	4.7	5.1	5.5	4.1	4.6	4.9
SW3	2.5	3.1	3.7	4.4	5.4	6.0	6.6	7.3	7.8	6.5	6.9	7.6

Wall Height 3000 mm (2801- 3100)

Brace Type	Bracing capacity (kN) for Unit Width (mm) of:											
	600	700	800	900	1000	1100	1200	1300	1400	1500	1600	1700
SW1	1.3	1.8	2.0	2.5	2.9	3.3	3.6	4.0	4.2	3.0	3.2	3.5
SW2	1.6	2.0	2.4	3.0	3.5	3.9	4.1	4.7	4.9	3.6	4.0	4.3
SW3	2.1	2.7	3.3	3.9	4.7	5.4	5.8	6.6	6.9	5.5	6.1	6.6

3. Having chosen which type of wall unit you need, go to the appropriate detail sheet in this guide for the construction details.

a. Stud size and grade

The stud size and grade given in these detail sheets has been determined for lateral wind raking resistance only. The studs may have to be larger for other direct loading conditions. Note that these stud minimums apply only to the outer stud on each side of the panel. All studs between the outer studs may be sized for the common studs condition.

b. Nailing for the tension braces

It is critical that the braces be wrapped around the plates and studs as shown in order to achieve the capacity of the strap. Tensioners are not required in any brace as long as it is installed straight. Pryda Timber Connector nails (35x3.15) may be substituted with power-driven galvanised 32x2.87 nails (min) through the steel strap.

c. Bottom plate details

The bottom plate width and thickness would determine the tie-down anchor capacity. The bottom plate size and grade (joint group) becomes important for type SW1 and some type SW2 bracing units and therefore should be prudently selected as specified in the data sheets.

d. Product substitution

Any specified minimum may be substituted using a stronger product as shown here.

Studs 35 F5 → 45 F5 → 35 F8 → 35 P10 → 45 F8 → 35 P12 → 45 P10 → 45 P12
 Studs Ties STS3 → ST3 → ST4
 Hold down bolts Ramset™ AnkaScrews™ AS12100H → Ramset™ AnkaScrews™ AS12150H

e. Anchorage details

The specified Ramset™ AnkaScrews™ may be substituted by an equivalent anchor to resist tie-down forces generated by the bracing unit at each end. The large washer must be used to spread the load around the bottom plate, and the anchor must be as close to the stud as possible (40mm +/- 10mm). For fixing in to timber sub-floor or upper floor, adopt details similar to Table 8.24; AS1684:2010

WORKED EXAMPLE

A single storeyed building with 2.4m high walls requires 50kN of wind bracing resistance in one direction. There are 8 walls which can have Pryda Angle Brace fitted to them with the shortest of these walls being 2.4m long. There are also 3/900mm and 4/600mm wide external walls near outer corners which we want to brace using Speedbrace (SDB). Will this work, and what bracing details are needed ?

- a) The normal walls with Pryda Angle Brace can resist 1.5 kN/m (see AS 1684.2 Table 8.18c).
 Total wall length available for angle bracing = $8 \times 2.4\text{m} = 19.2\text{m}$
 Total resistance provided by angle bracing = $19.2\text{m} \times 1.5 \text{ kN/m} = 28.8 \text{ kN}$

- b) So the resistance to be provided by the remaining walls = $50.0 - 28.8 = 21.2 \text{ kN}$.

- c) Try single SDB :
 Capacity of 3/ 900 wide walls = $3 \times 3.4 \text{ kN} = 10.2 \text{ kN}$ (see Table SW2/0609)
 Capacity of 4/ 600 wide walls = $4 \times 1.9 \text{ kN} = 7.6 \text{ kN}$ (see Table SW2/0609)
 Total capacity of these 7 short walls = $17.8 \text{ kN} < 21.2 \text{ kN}$ No good

- d) Try double SDB on the 900 walls :
 Capacity of 3/ 900 wide walls = $3 \times 4.8 \text{ kN} = 14.4 \text{ kN}$ (see Table SW3/0609)
 Capacity of 4/ 600 wide walls = $4 \times 1.9 \text{ kN} = 7.6 \text{ kN}$ (see Table SW2/0609)
 Total capacity of these 7 short walls = $22.0 \text{ kN} > 21.2 \text{ kN}$ OK

Notes: (1) The capacity of the short walls is achieved by attention to the way in which the straps are fixed at the ends and by the anchor bolts. The normal wind bracing construction practice in AS1684 is limited by two nails at each end of the angle brace into the face of the plates, and the use of simple fixing systems of the bottom plate.

(2) The resistance of the walls with angle bracing in them could have been increased if there was more width available. For example, if the bracing could be used over a 2.7m width of wall instead of 2.4m, then the wind resistance capacity in these walls would increase to $8 \times 2.7 \times 1.5 = 32.4 \text{ kN}$, and now the single SDB option in the short walls would be $32.4 + 17.8 = 50.2 \text{ kN} > 50.0 \text{ kN}$ OK.

(1) Type SW1 - 600 to 900 mm Walls

Single Strap Brace (SB103) for Short Wall Unit - SW1/0609

This unit is specially designed for bracing of short walls of 600 mm to 900 mm length and heights up to 3000 mm. It has Unit Bracing Capacities as tabulated below.

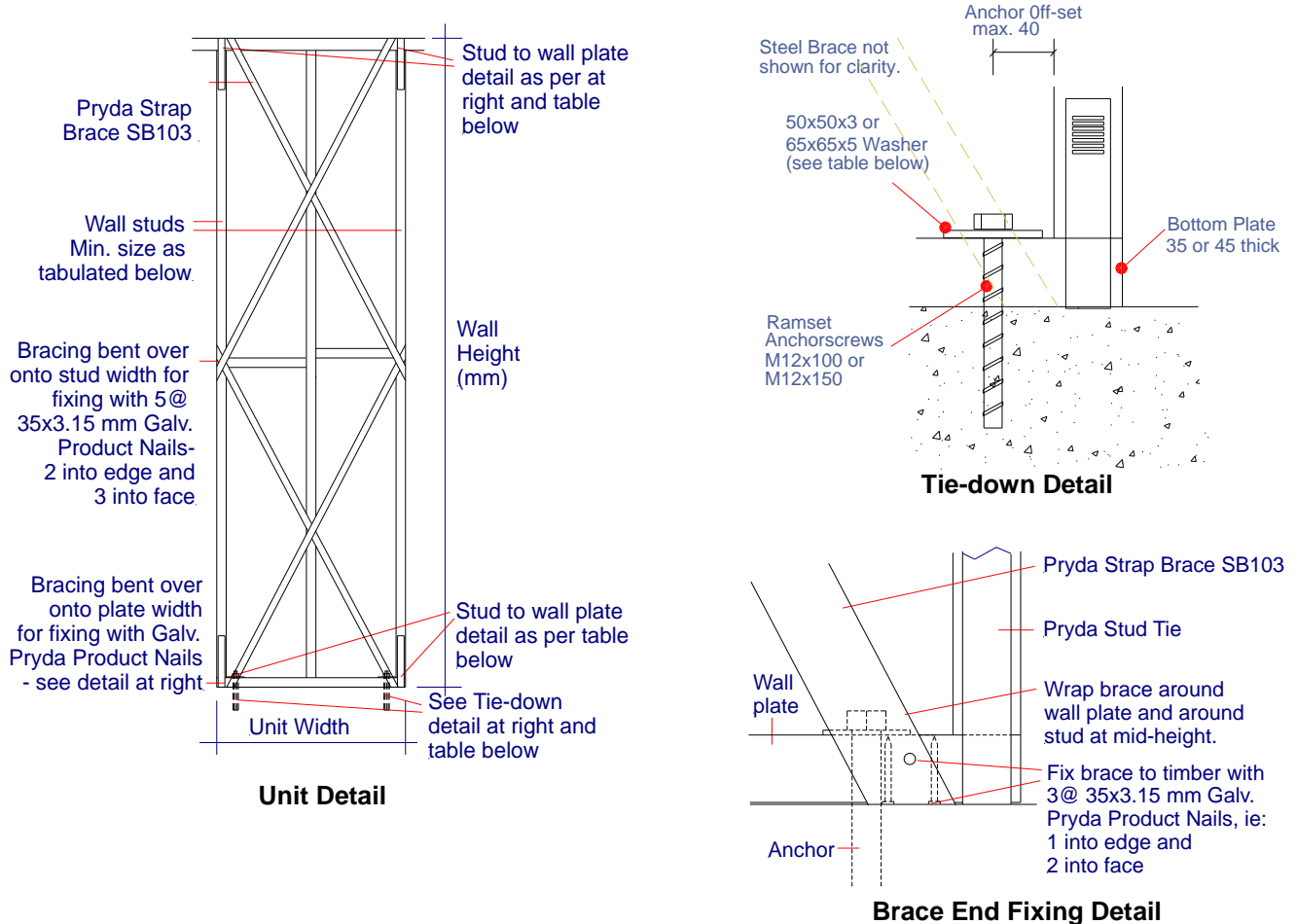

Construction

Brace	Wall Height	Minimum Wall Stud	Tie down Anchor	Stud Tie
Strap Brace SB103	2400	70x35 F5; 90x35 F5	Ramset™ AnkaScrews™ AS12100H or AS12150H	STS3 or ST3 .. at all four corners of unit
	2700	70x45 F5; 90x35 F5		
	3000	70x35 F8; 90x35 F5		

Note: Use of SB083

SB083 may be used in lieu of SB103 for Type SW1 bracing units provided the capacities are reduced by 20%.

Tie-down Anchor Details:

Bottom Plate	Anchor Code	Length	Anchor dia.	Min. Embedment	Min. washer
70x35 or 90x35 Internal Walls	AS12100H	100	M12	60	JD5 – 65x65x5.0 (OW12/65S) JD4 – 50x50x3.0 (OW12/56S)
70x45 or 90x45 Internal Walls & All External Walls	AS12150H	150	M12	100	

Unit Bracing Capacities for SW1/0609:

Wall Height (mm)	2400				2700				3000			
	600	700	800	900	600	700	800	900	600	700	800	900
Unit Width (mm)	600	700	800	900	600	700	800	900	600	700	800	900
External walls (kN)	1.6	2.0	2.5	2.8	1.4	1.7	2.2	2.5	1.1	1.5	1.8	2.2
Internal walls (kN)	1.8	2.2	2.7	3.1	1.6	1.9	2.4	2.8	1.3	1.8	2.0	2.5

(2) Type SW2 - 600 to 900 mm Walls

Single Speedbrace / Strap Brace SB123 for Short Wall Unit – SW2/0609

This unit is specially designed for bracing of short walls of 600 mm to 900 mm length and heights up to 3000 mm. It has Unit Bracing Capacities as tabulated below.

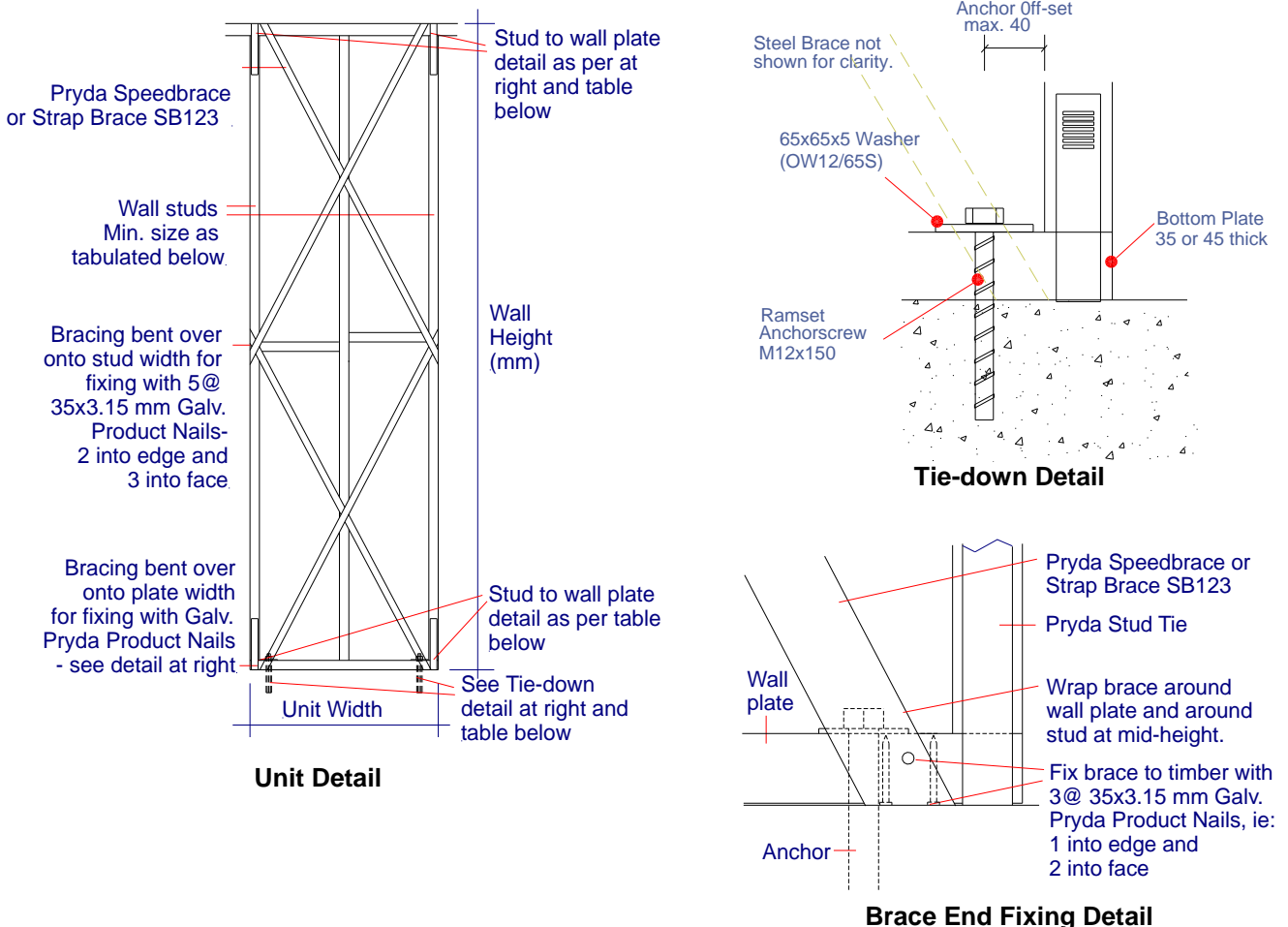

Construction

Brace	Wall Height	Minimum Wall Stud	Tie down Anchor	Stud Tie
Speedbrace SDB... or Strap Brace SB123	2400	70x35 F5; 90x35 F5	Ramset™ AnkaScrews™ AS12150H	STS3 for all options except use ST3 for 2400 wall height and 800-900 mm width .. at all four corners of unit
	2700	70x45 F5; 90x35 F5		
	3000	70x45 P10; 90x35 F5		

Tie-down Anchor Details:

Bottom Plate	Anchor Code	Length	Anchor dia.	Min. Embedment	Min. washer
For min 70 width & max 45 thickness	AS12150H	150	M12	100	65x65x5.0 (OW12/65S)

Unit Bracing Capacities for SW2/0609:

Wall Height (mm)	2400				2700				3000			
	600	700	800	900	600	700	800	900	600	700	800	900
Unit Width (mm)	600	700	800	900	600	700	800	900	600	700	800	900
External walls (kN)	1.9	2.5	3.0	3.4	1.6	2.1	2.6	3.0	1.4	1.8	2.2	2.7
Internal walls (kN)	2.1	2.7	3.2	3.7	1.8	2.3	2.8	3.3	1.6	2.0	2.4	3.0

(3) Type SW3 - 600 to 900 mm Walls

Double Speedbrace / Strap Brace SB123 for Short Wall Unit – SW3/0609

This unit is specially designed for bracing of short walls of 600 mm to 900 mm length and heights up to 3000 mm. It has Unit Bracing Capacities as tabulated below.

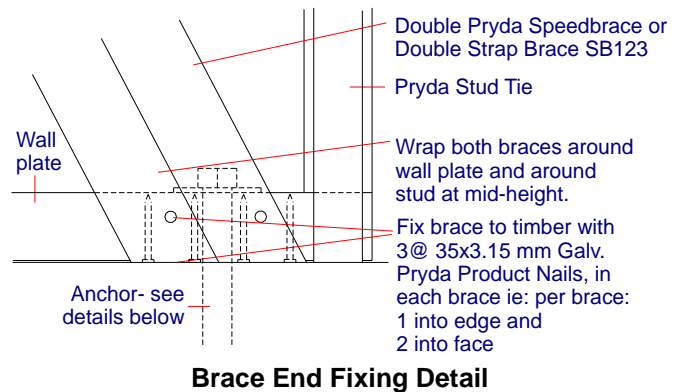
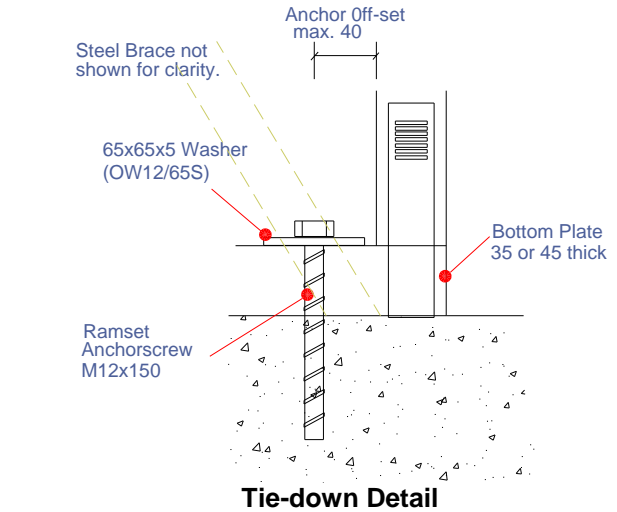
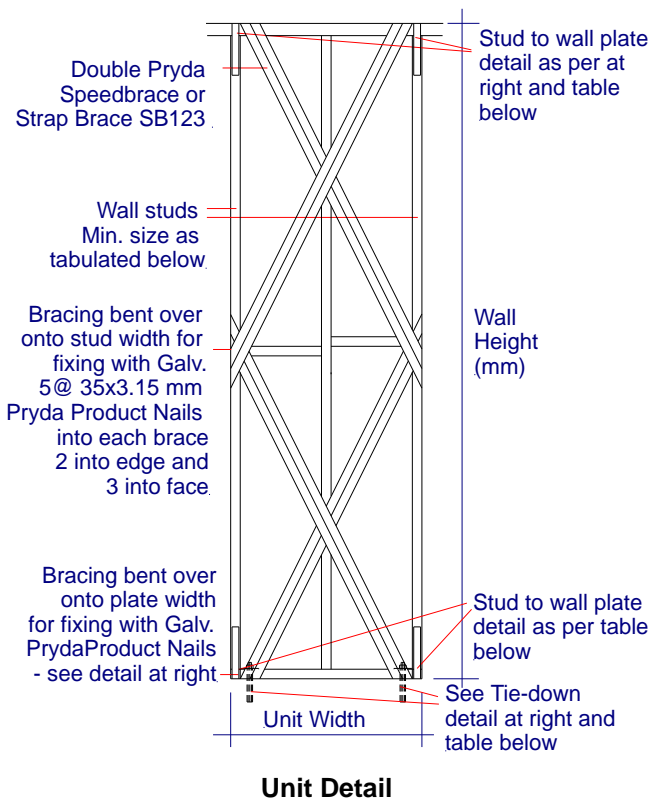

Construction

Brace	Wall Height	Minimum Wall Stud	Tie down Anchor	Stud Tie
Double Speedbrace SDB... or Double Strap Brace SB123	2400	70x35 F8; 90x35 F5	Ramset™ AnkaScrews™ AS12150H	ST3 ..at all four corners of unit
	2700	70x45 P10; 90x35 F5		
	3000	70x45 P10; 90x35 F5		

Tie-down Anchor Details:

Bottom Plate	Anchor Code	Length	Anchor dia.	Min. Embedment	Min. washer
For min 70 width & max 45 thickness	AS12150H	150	M12	100	65x65x5.0 (OW12/65S)

Unit Bracing Capacities for SW3/0609:

Wall Height (mm)	2400				2700				3000			
Unit Width (mm)	600	700	800	900	600	700	800	900	600	700	800	900
External walls (kN)	2.6	3.3	4.1	4.8	2.2	2.9	3.5	4.1	1.9	2.5	3.1	3.6
Internal walls (kN)	2.8	3.5	4.3	5.1	2.5	3.1	3.7	4.4	2.1	2.7	3.3	3.9

(4) Type SW1 - 1000 to 1400 mm Walls

Single Strap Brace SB103 for Short Wall Unit – SW1/1014

This unit is specially designed for bracing of short walls of 1000 mm to 1400 mm length and heights up to 3000 mm. It has Unit Bracing Capacities as tabulated below.

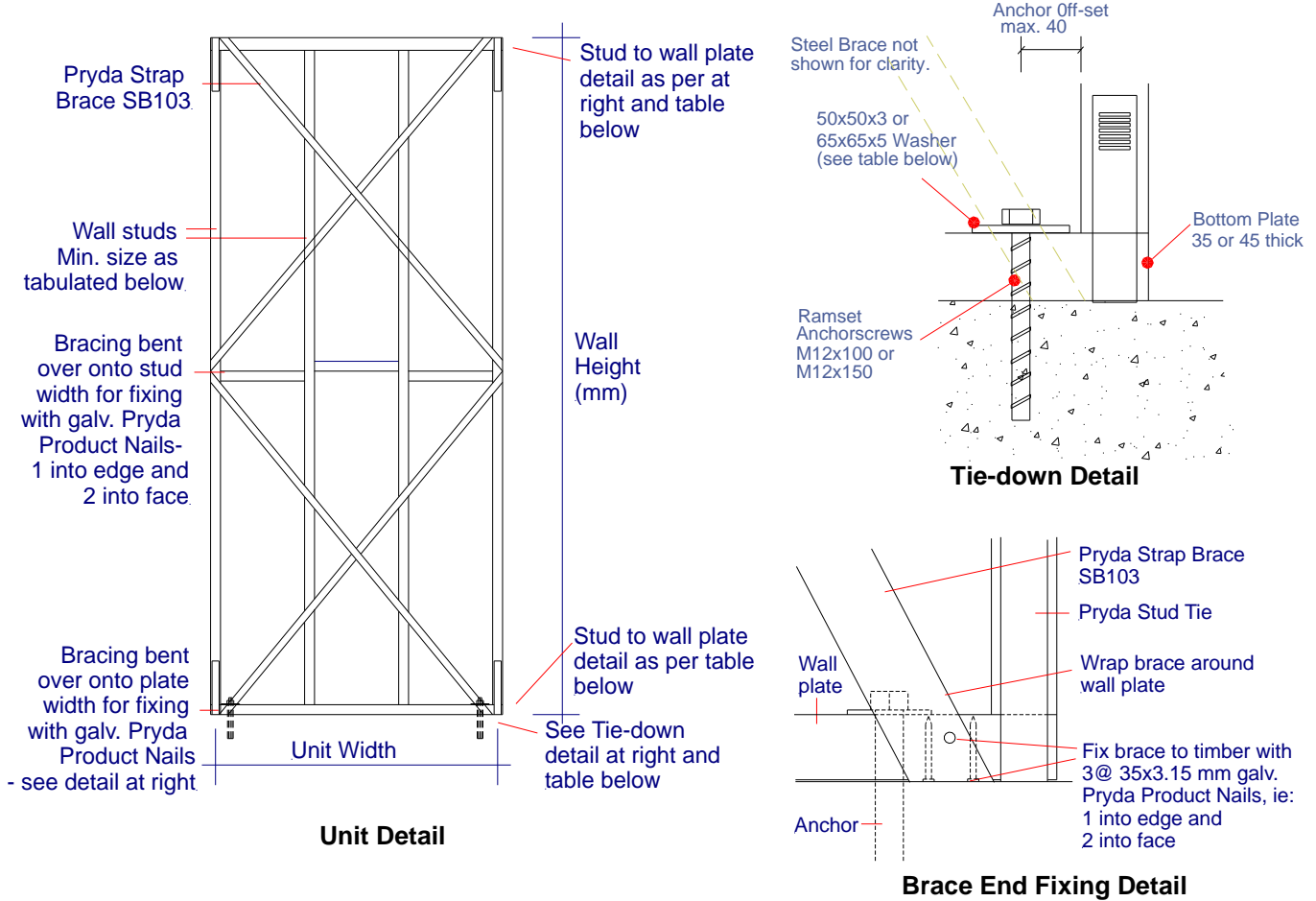

Construction

Brace	Wall Height	Minimum Wall Stud	Tie down Anchor	Stud Tie
Pryda Strap Brace SB103	2400	70x35 F5; 90x35 F5	Ramset™ AnkaScrews™ AS12100H or AS12150H	STS3 or ST3 ..at all four corners of unit
	2700	70x45 F5; 90x35 F5		
	3000	70x35 F8; 90x35 F5		

Note: Use of SB083

SB083 may be used in lieu of SB103 for Type SW1 bracing units provided the capacities are reduced by 20%.

Tie-down Anchor Details:

Bottom Plate	Anchor Code	Length	Anchor dia.	Min. Embedment	Min. washer
70x35 or 90x35 Internal Walls only	AS12100H	100	M12	60	JD5 – 65x65x5.0 (OW12/65S) JD4 – 50x50x3.0 (OW12/56S)
70x45 or 90x45 Internal Walls & All External Walls	AS12150H	150	M12	100	

Unit Bracing Capacities for SW1/1014:

Wall Height (mm)	2400					2700					3000				
	1000	1100	1200	1300	1400	1000	1100	1200	1300	1400	1000	1100	1200	1300	1400
Unit Width (mm)	1000	1100	1200	1300	1400	1000	1100	1200	1300	1400	1000	1100	1200	1300	1400
External walls (kN)	3.3	3.7	4.0	4.1	4.3	3.0	3.3	3.6	3.9	4.1	2.6	3.0	3.2	3.5	3.7
Internal walls (kN)	3.7	4.0	4.3	4.5	4.7	3.3	3.7	4.0	4.2	4.5	2.9	3.3	3.6	4.0	4.2

(5) Type SW2 - 1000 to 1400 mm Walls

Single Speedbrace / Strap Brace SB123 for Short Wall Unit –SW2/1014

This unit is specially designed for bracing of short walls of 1000 mm to 1400 mm length and heights up to 3000 mm. It has Unit Bracing Capacities as tabulated below.

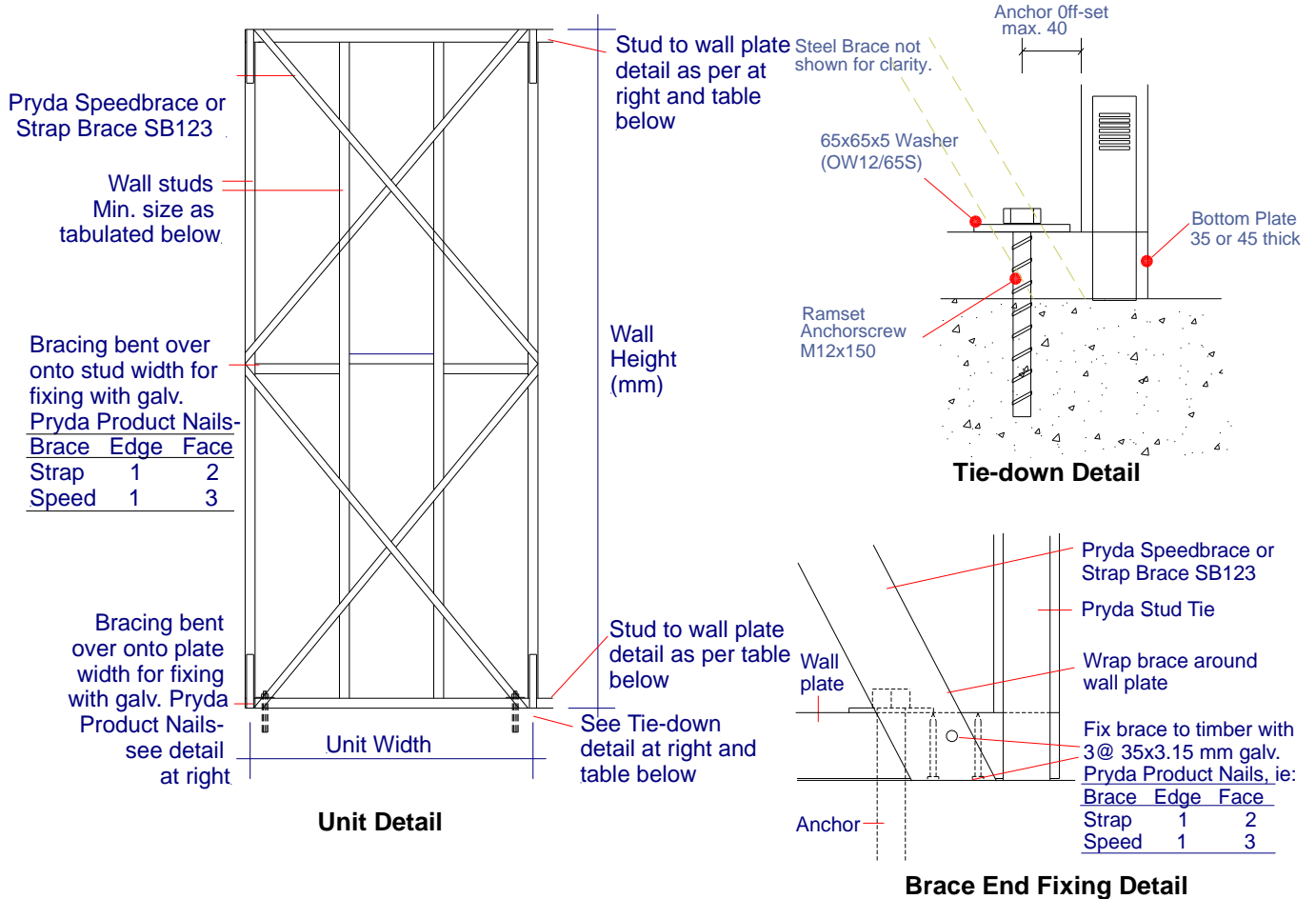

Construction

Brace	Wall Height	Minimum Wall Stud	Tie down Anchor	Stud Tie
Speedbrace SDB or ... Pryda Strap Brace SB123	2400	70x35 F5; 90x35 F5	Ramset™ AnkaScrews™ AS12150H	ST3 ..at all four corners of unit
	2700	70x35 F8; 90x35 F5		
	3000	70x45 F8; 90x35 F5		

Tie-down Anchor Details (for both External & Internal walls):

Bottom Plate	Anchor Code	Length	Anchor dia.	Min. Embedment	Min. washer
For min 70 width & max 45 thickness	AS12150H	150	M12	100	65x65x5.0 (OW12/65S)

Unit Bracing Capacities for SW2/1014:

Wall Height (mm)	2400					2700					3000				
	1000	1100	1200	1300	1400	1000	1100	1200	1300	1400	1000	1100	1200	1300	1400
Unit Width (mm)	1000	1100	1200	1300	1400	1000	1100	1200	1300	1400	1000	1100	1200	1300	1400
External walls (kN)	4.1	4.5	4.9	5.1	5.4	3.6	4.1	4.4	4.7	5.1	3.1	3.6	3.9	4.3	4.5
Internal walls (kN)	4.4	4.8	5.3	5.5	5.8	3.9	4.4	4.7	5.1	5.5	3.5	3.9	4.1	4.7	4.9

(6) Type SW3 - 1000 to 1400 mm Walls

Double Speedbrace / Strap Brace SB123 for Short Wall Unit – SW 3/1014

This unit is specially designed for bracing of short walls of 1000 mm to 1400 mm length and heights up to 3000 mm. It has Unit Bracing Capacities as tabulated below.

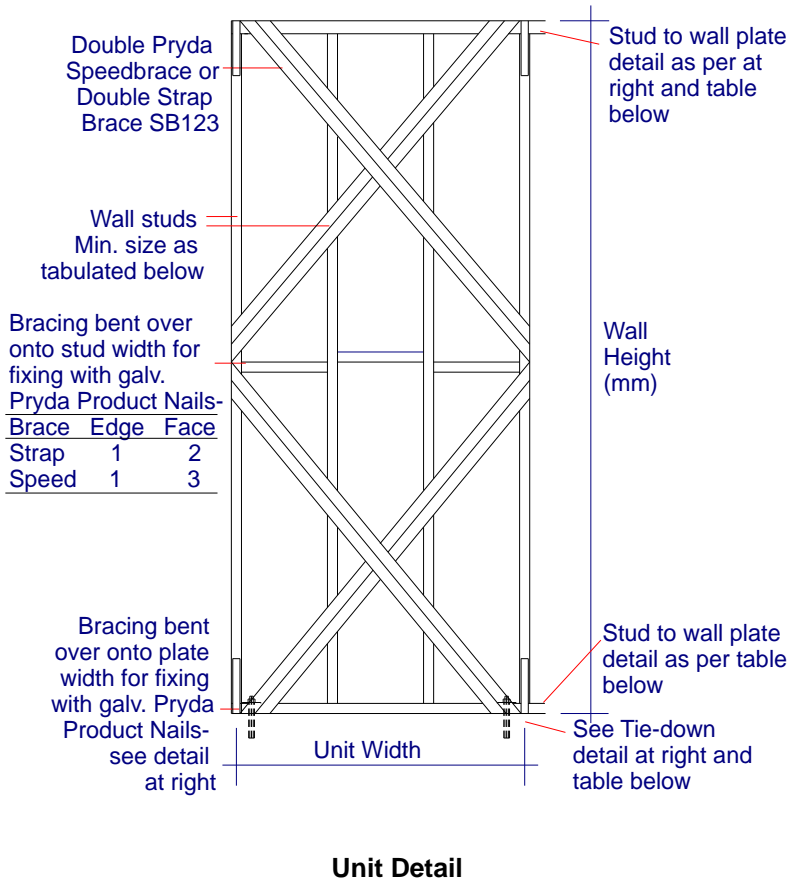

Unit Detail

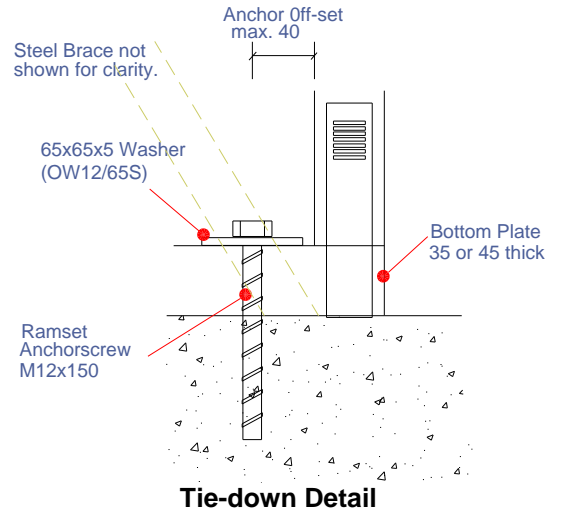

Tie-down Detail

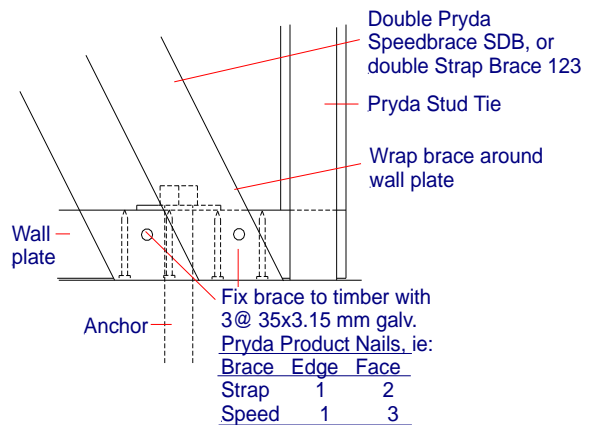

Brace End Fixing Detail

Construction

Brace	Wall Height	Minimum Wall Stud	Tie down Anchor	Stud Tie
Double Speedbrace SDB... or Double Strap Brace SB123	2400	70x35 F8; 90x35 F5	Ramset™ AnkaScrews™ AS12150H	ST4 ..at all four corners of unit
	2700	70x45 P12; 90x35 F5		
	3000	70x45 P12; 90x35 F8		

Tie-down Anchor Details:

Bottom Plate	Anchor Code	Length	Anchor dia.	Min. Embedment	Min. washer
For min 70 width & max 45 thickness	AS12150H	150	M12	100	65x65x5.0 (OW12/65S)

Unit Bracing Capacities for SW3/1014:

Wall Height (mm)	2400					2700					3000				
Unit Width (mm)	1000	1100	1200	1300	1400	1000	1100	1200	1300	1400	1000	1100	1200	1300	1400
External walls (kN)	5.8	6.5	6.9	7.4	8.0	5.1	5.6	6.2	6.9	7.4	4.4	5.0	5.4	6.2	6.5
Internal walls (kN)	6.1	6.8	7.3	7.8	8.4	5.4	6.0	6.6	7.3	7.8	4.7	5.4	5.8	6.6	6.9

(7) Type SW1 - 1500 to 1800 mm Walls

Single Strap Brace SB103 for Short Wall Unit – SW1/1518

This unit is specially designed for bracing of short walls of 1500 mm to 1800 mm length and heights up to 3000 mm. It has Unit Bracing Capacities as tabulated below.

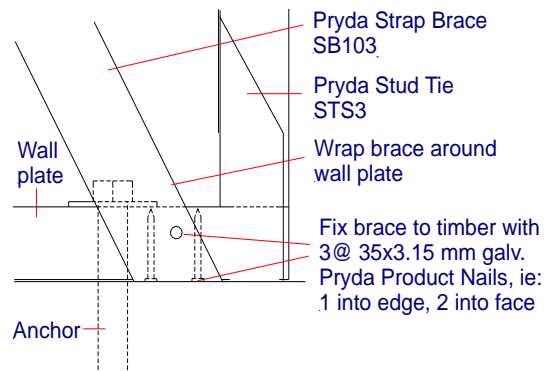
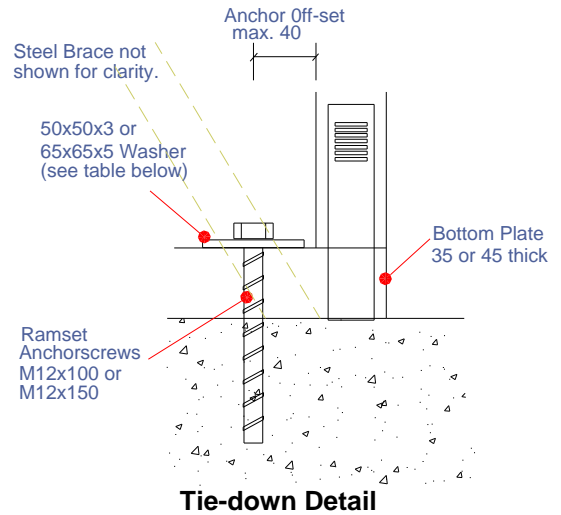
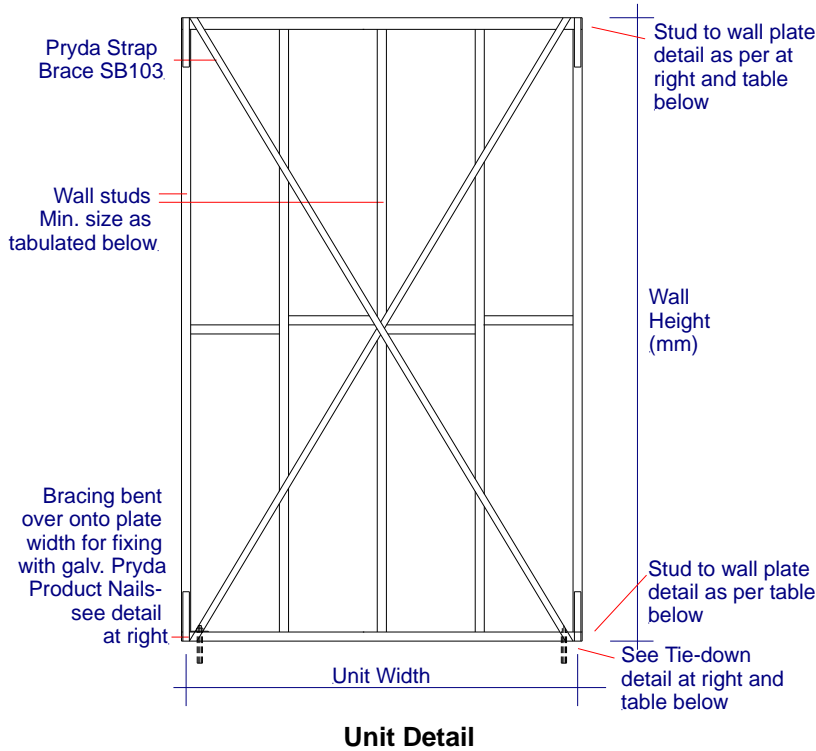

Note: Use of SB083
SB083 may be used in lieu of SB103 for Type SW1 bracing units provided the capacities are reduced by 20%.

Construction

Brace	Wall Height	Minimum Wall Stud	Tie down Anchor	Stud Tie
Strap Brace SB103	2400	70x35 F5 or 90x35 F5	Ramset™ AnkaScrews™ AS12100H or AS12150H	STS3 or ST3 ..at all four corners of unit
	2700	70x35 F5 or 90x35 F5		
	3000	70x35 F5 or 90x35 F5		

Tie-down Anchor Details:

Bottom Plate	Anchor Code	Length	Anchor dia.	Min. Embedment	Min. washer
70x35 or 90x35 Internal Walls	AS12100H	100	M12	60	JD5 – 65x65x5.0 (OW12/65S) JD4 – 50x50x3.0 (OW12/56S)
70x45 or 90x45 Internal Walls & All External Walls	AS12150H	150	M12	100	

Unit Bracing Capacities for SW1/1517:

Wall Height (mm)	2400				2700				3000			
	1500	1600	1700	1800	1500	1600	1700	1800	1500	1600	1700	1800
Unit Width (mm)	1500	1600	1700	1800	1500	1600	1700	1800	1500	1600	1700	1800
External walls (kN)	3.3	3.6	3.9	See Note	2.9	3.2	3.5	See Note	2.5	2.8	3.0	See Note
Internal walls (kN)	3.8	4.1	4.4	See Note	3.4	3.7	4.0	See Note	3.0	3.2	3.5	See Note

Note: For unit widths of 1800mm or greater, refer Pryda Bracing Guide or AS1684 for unit capacities

(8) Type SW2 - 1500 to 1800 mm Walls

Single Speedbrace / Strap Brace SB123 for Short Wall Unit – SW2/1518

This unit is specially designed for bracing of short walls of 1500 mm to 1800 mm length and heights up to 3000 mm. It has Unit Bracing Capacities as tabulated below.

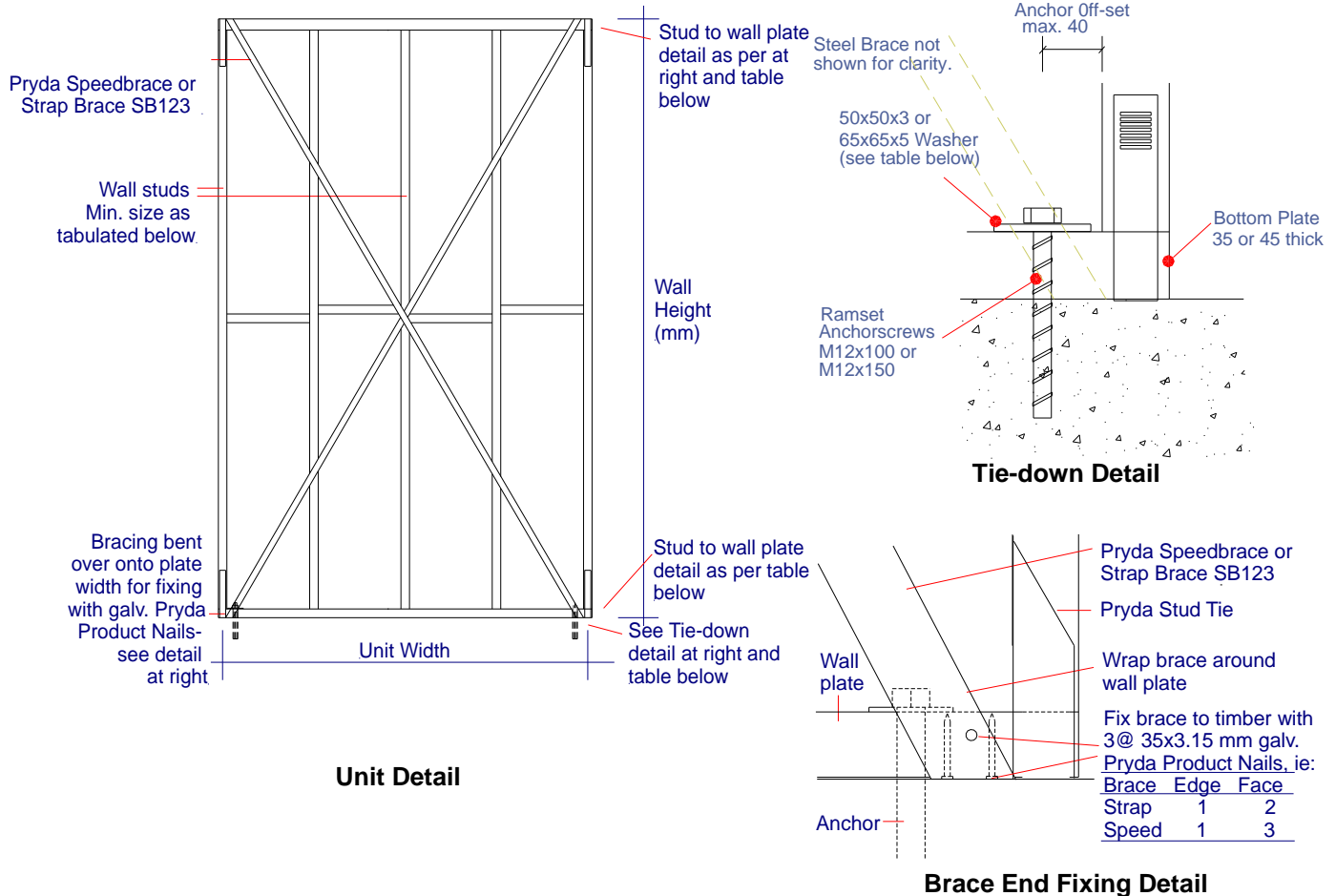

Construction

Brace	Wall Height	Minimum Wall Stud	Tie down Anchor	Stud Tie
Speedbrace SDB... or Strap Brace SB123	2400	70x35 F5; 90x35 F5	Ramset™ AnkaScrews™ AS12100H or AS12150H	STS3 or ST3 ..at all four corners of unit
	2700	70x45 F8; 90x35 F5		
	3000	70x45 F8; 90x35 F5		

Tie-down Anchor Details:

Bottom Plate	Anchor Code	Length	Anchor dia.	Min. Embedment	Min. washer
70x35 or 90x35	AS12100H	100	M12	60	JD5 – 65x65x5.0 (OW12/65S)
70x45 or 90x45	AS12150H	150	M12	100	JD4 – 50x50x3.0 (OW12/56S)

Unit Bracing Capacities for SW2/1518:

Wall Height (mm)	2400				2700				3000			
	1500	1600	1700	1800	1500	1600	1700	1800	1500	1600	1700	1800
Unit Width (mm)	1500	1600	1700	1800	1500	1600	1700	1800	1500	1600	1700	1800
External walls (kN)	4.2	4.5	4.9	See Note	3.7	4.1	4.4	See Note	3.2	3.5	3.8	See Note
Internal walls (kN)	4.7	5.0	5.4	See Note	4.1	4.6	4.9	See Note	3.6	4.0	4.3	See Note

Note: For unit widths of 1800mm or greater, refer Pryda Bracing Guide or AS1684 for unit capacities

(9) Type SW3 - 1500 to 1800 mm Walls

Double Speedbrace / Strap Brace SB123 for Short Wall Unit- SW3/1518

This unit is specially designed for bracing of short walls of 1500 mm to 1800 mm length and heights up to 3000 mm. It has Unit Bracing Capacities as tabulated below.

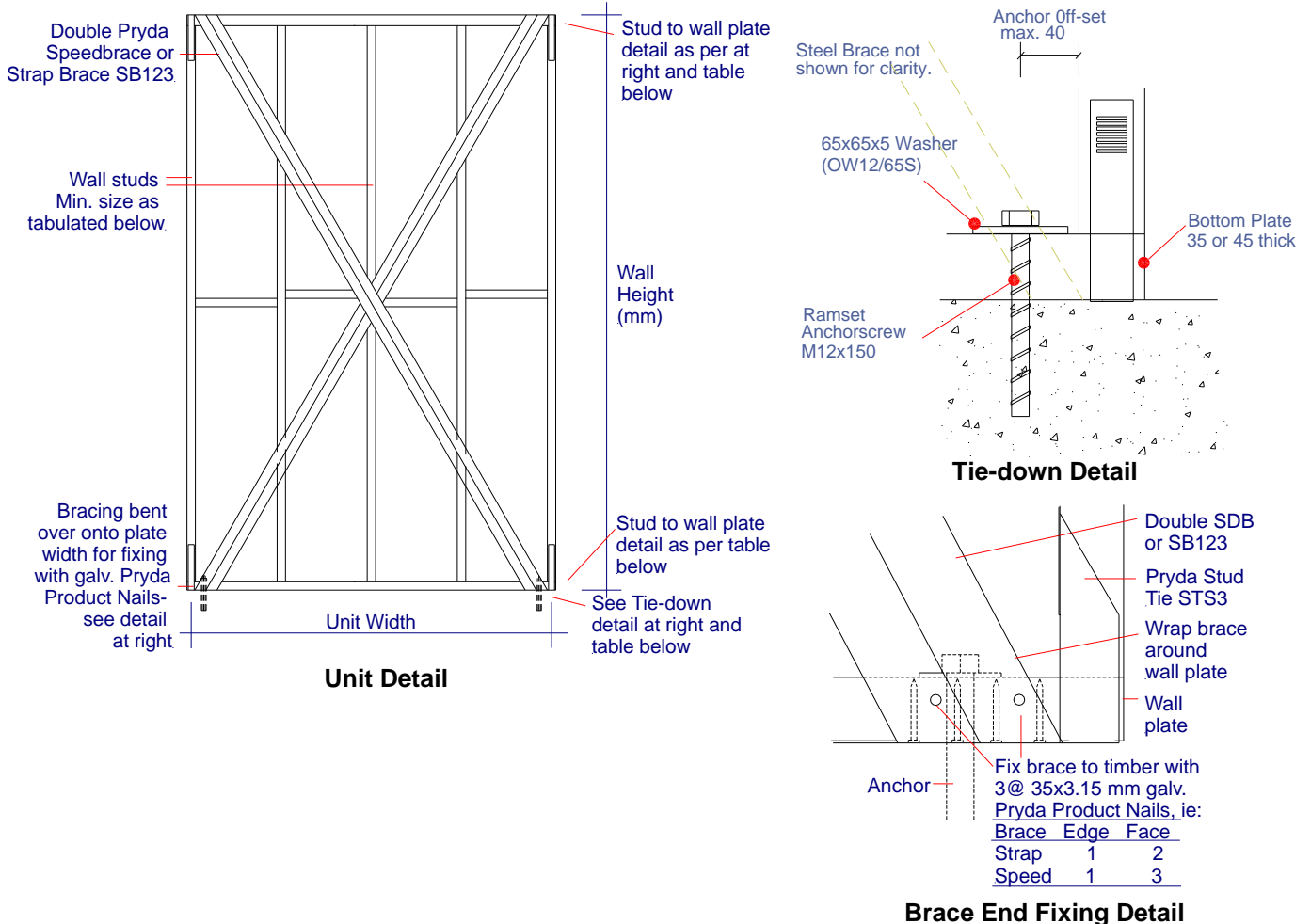

Construction

Brace	Wall Height	Minimum Wall Stud	Tie down Anchor	Stud Tie
Double Speedbrace SDB or double Strap Brace SB123	2400	70x45 F5; 90x35 F5	Ramset™ AnkaScrews™ AS12150H	STS3 ..at all four corners of unit
	2700	70x35 P10; 90x35 F5		
	3000	70x35 P12; 90x35 F8		

Tie-down Anchor Details:

Bottom Plate	Anchor Code	Length	Anchor dia.	Min. Embedment	Min. washer
For min 70 width & max 45 thickness	AS12150H	150	M12	100	65x65x5.0 (OW12/65S)

Unit Bracing Capacities for SW3/1518:

Wall Height (mm)	2400				2700				3000			
	1500	1600	1700	1800	1500	1600	1700	1800	1500	1600	1700	1800
Unit Width (mm)	1500	1600	1700	1800	1500	1600	1700	1800	1500	1600	1700	1800
External walls (kN)	6.7	7.6	8.1	See Note	6.1	6.4	7.1	See Note	5.0	5.6	6.1	See Note
Internal walls (kN)	7.1	8.0	8.6	See Note	6.5	6.9	7.6	See Note	5.5	6.1	6.6	See Note

Note: For unit widths of 1800mm or greater, refer Pryda Bracing Guide or AS1684 for unit capacities

Tie-down Anchors:

Suitable tie-down anchors for wall bracing units are:

Application	Suitable Anchors
External walls	Ramset™ AnkaScrews™ or equivalent Ramset™ Chemset™ Injection 100 and 800 series or equivalent Ramset™ Chemset™ Spin Capsules or equivalent
Internal walls	Ramset™ AnkaScrews™ and other Chemset™ Anchors as above Ramset™ Dynabolt™ Anchors or equivalent Ramset™ Trubolt™ Anchors or equivalent

For Design capacities and installation instructions on the above anchors, visit Ramset at www.ramset.com.au or contact Ramset direct.

Only Ramset™ AnkaScrews™ M12 x100 (AS12100H) is available from Pryda. M12 x 150 (AS12150H) may be obtained from Ramset retail channels. The design capacities for these anchors are provided below.

Design Capacities of Ramset™ AnkaScrews™

Ramset™ AnkaScrews™ through 35mm thick bottom plates

Part Code	Anchor Size	Effective Anchor Depth	Uplift Capacity (ΦN_j) (kN)			Minimum Concrete Thickness (mm)
			External Walls		Internal Walls	
			70 mm	90 mm		
AS12100H	M12 x 100	60	5.2	5.8	10.4	85
AS12150H	M12 x 150	110	13.1	14.3	26.1	135

Ramset™ AnkaScrews™ through 45mm thick bottom plates

Part Code	Anchor Size	Effective Anchor Depth	Uplift Capacity (ΦN_j) (kN)			Minimum Concrete Thickness (mm)
			External Walls		Internal Walls	
			70 mm	90 mm		
AS12100H	M12 x 100	50	3.9	4.3	7.8	75
AS12150H	M12 x 150	100	11.3	12.5	22.6	125

Design capacities in the above tables are based on:

- Grade 20 concrete minimum
- Minimum anchor edge distances- external walls of 35 mm for 70 mm wall frames, 45 mm for 90 mm frames
- Minimum anchor edge distances- internal walls = 75 mm
- Washers of sufficient capacity, as tabulated in the following table, must be installed between the anchor head and bottom wall plate.
- **The final tie-down capacity is limited by the minimum of Anchor and the washer capacities.**

Minimum Washer Sizes for Tie-down Anchors

Square Washer Size (mm)	Round Washer Size (mm)	Washer Type and Pryda Code	Capacity (ΦN_j) (kN) for Joint Group:	
			JD5	JD4
50 x 50 x 3.0	55 dia x 3.0	Standard OW12/56S	8.4	10.5
65 x 65 x 5.0	75 dia x 5.0	Heavy Duty OW12/65S	20.8	26.1