

FULL STIRRUP POST ANCHOR WITH SOLID STEM

FEATURES AND BENEFITS

ECONOMICAL: Light weight design with cranked solid stem to better resist uplift.

EASY: Simply embed stem into wet concrete with full U stirrup post support using 2 x M10 bolts.

STRONG: Hot dip galvanised coating after manufacture and made from 4mm steel. Full CFW solid stem to saddle.

SPECIFICATIONS

STEEL	G250
THICKNESS	4mm
CORROSION RESISTANCE	HDG500 (Hot Dipped Galvanised 500g/m ²)
STEM HEIGHT	150mm, 200mm and 300mm
POST SIZE	90mm, 100mm

FASTENER REQUIRED

POST STIRRUP TO TIMBER POST	M10 4.6 grade galvanised hex head bolts.
	M10 x 50mm 4.6 grade galvanised coach screws.
POST BASE TO CONCRETE	Nil – Set in to wet concrete.



AS1684, AS1720 & AS4055 COMPLIANT

- Designed in accordance with Pryda testing and relevant Australian standards
- Engineering computations in accordance with the relevant Australian standards

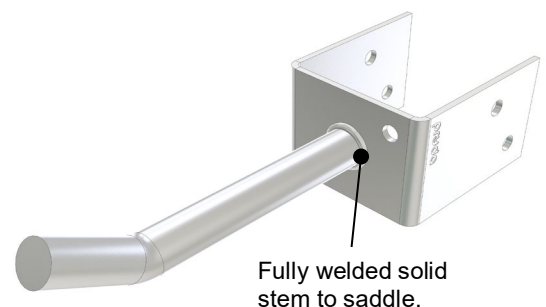
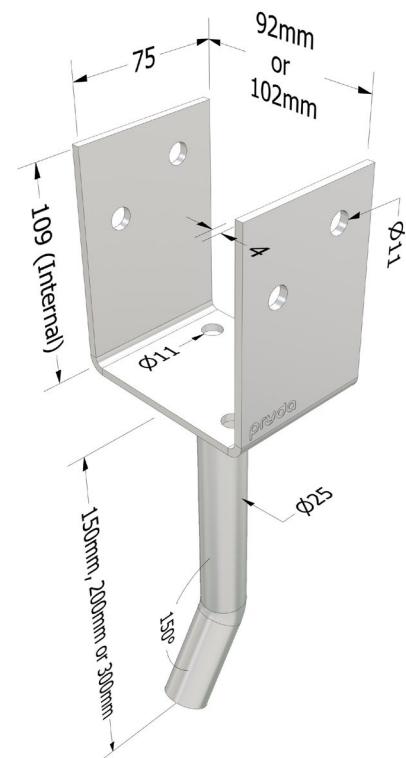

RANGE

PRODUCT CODE	MATERIAL	STEM HEIGHT (mm)	POST SIZE (mm)	BOLT HOLE SIZE	QTY
PSFW15090/6	G250 Steel Hot Dip Galvanised (500 g/m ²)	150	90	M10	6
PSFW20090/6		200	90	M10	6
PSFW30090/4		300	90	M10	4
PSFW300100/4		300	100	M10	4

DURABILITY

Pryda post anchors are Hot-dipped Galvanized to standard AS/NZS 4680. Routine inspection and clearing any debris around anchor are an integral part of the ongoing care and maintenance.

STORAGE AND HANDLING

Prior to use, the Pryda products shall be stored in a weatherproof environment and protected from moisture. Care must be taken to avoid any damage to the surface of the product protective galvanised coating and profile that may impact performance.

APPLICATION AND SCOPE OF USE

Typical application for all Pryda Post Anchors is for attached open verandah or similar structures for dwellings. All other usage must be verified/designed by consulting Structural Engineer.

DESIGN CAPACITIES

Limit State Design capacities (ΦN_j) for Pryda Standard Post Anchors resisting wind uplift loads are as follows:

FIXINGS	POST (mm)	UPLIFT CAPACITIES FOR VARYING JOINT GROUPS (kN)		
		JD5	JD4	JD3
2 x M10 bolts	90	12 ⁽⁴⁾	12 ⁽⁴⁾	12 ⁽⁴⁾
4 x M10 x 50mm coach screws		6.7 ⁽⁴⁾	10.6 ⁽⁴⁾	12 ⁽⁴⁾

Notes:

- The design loads tabulated above require that:
 - the timber post must bear on the Post Anchor base.
 - all post sizes to be a minimum of 90 x 90 mm section UNO.
 - all anchors must be installed plumb.
 - for all bolt down anchors, support foundation must be flat, level, and supporting base plate fully.
- Select design capacity according to the standard used for determining the design loads.
- Specified capacities are for concentric vertical load transfer only. Refer to each post anchor notes for recommended capacities for eccentrically loaded conditions with selected post anchors only.
- The base concrete and fixings to the concrete must provide sufficient resistance to the uplift forces and dead +live loads. Uplift capacities stated in this document are stated for steel and timber post ONLY, these capacities may be limited by anchoring methods to the supporting foundation i.e., fastener type, wet concrete embedment depth and concrete design. This should be verified by the Project Engineer or designer prior to installation.**
- Wind uplift capacities are based on the AS/NZS 1170.2 wind code.
- Post Anchors should NOT be assumed to contribute towards lateral bracing/ raking stability of a structure in decks or stumps in sub-structure, unless pre-approved by a Structural Engineer.
- Post Anchors are not Intended to be used for cantilever posts, balustrades, and free standing structures. Carports and gazebo. Unless designed and approved by a consulting structural Engineer.
- Post must be laterally restrained at top, installed centrally to anchor, and deemed to be "fit for purpose" by the project Engineer.
- It is recommended to slope the foundation away from the anchor to prevent water pooling at the base.
- Do not cover exposed base plate and stem with debris or obstacles that will facilitate collection of debris around anchor base.
- Maximum post height 3m and ultimate limit state wind speed not exceeding 50 m/s unless noted otherwise.
- Local settlement, ground water and soil reactivity will cause isolated concrete footings to 'TILT' and therefore induce bending into the post stirrup stem. Isolated footing should be restricted to stable soil. i.e.. Class A and S foundation classification to AS2870.

IMPORTANT: READ THIS DATASHEET IN CONJUNCTION WITH PRYDA POST ANCHORS GUIDE AND REFER TO GENERAL NOTES AND LIMITATIONS.

INSTALLATION

It is essential that the concrete design with selected solid stem length embedment exceeds the expected uplift load. Anchor to foundation design to be determined by consulting project Engineer to suit design application, foundation type, and deem fit for purpose. The design engineer should ensure the structural element can support the intended design loads.

STEP 1



- Pour concrete as per concrete design by consulting project Engineer's details.
- Mark centre location of post position.
- Ensure adequate concrete edge distance set back.
- Concrete foundation support to be level horizontally.
- Seek advice from your consulting project Engineer.

STEP 2

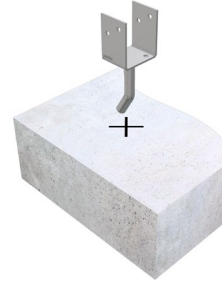

- While concrete is wet, orientate selected anchor as required over mark and firmly insert solid stem in to concrete.
- Embed selected anchor to required depth design by consulting project Engineer.
- Vibrate concrete as required to ensure air pockets around stem are absent and concrete compacted to required density.

STEP 3



- Ensure anchor is vertically plumb.
- Leave anchor until recommended concrete curing time have lapsed.

STEP 4



- Place timber post centrally into Post Anchor stirrup for direct bearing on stirrup base.
- Ensure both post anchor and post are vertically plumb.

STEP 5



- Drill through post using saddle holes. Ensure drill through holes are horizontally level and perpendicular to saddle.
- For coach screws, drill pilot holes to the length of selected screws.

STEP 6



- Insert bolt through saddle and passing through timber post. A minimum of 2 x thread pitch should extend beyond the outward surface of the nut.
- Install nut and securely fasten.

INSTALLATION TIPS

FOUNDATION SLOPE

- It is recommended to slope foundations away from the base of the Post Anchor all around.
- Avoid water pooling and buildup of debris around anchor base.
- Not suitable for foundation that is at the same level as natural ground unless deemed fit for purpose and approved by consulting design Engineer.
- Routinely clear away debris or any obstructions at anchor base on a regular basis.
- Tiling or paving around anchor is not recommended as this may result in a recess space around anchor that may facilitate water pooling and debris buildup.

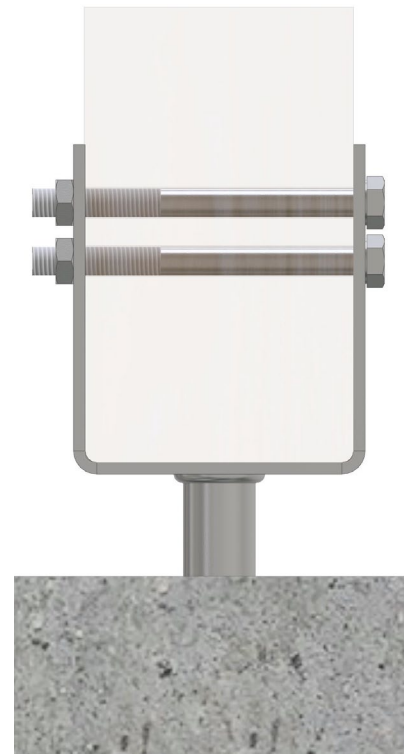

BOLT LENGTH

- When using hex head bolts for fastening your post, it is recommended to use a length 20mm longer than post side or have a minimum of 2x thread pitch extend beyond the outward surface of the hex nut.
- Account for the thickness of the saddle, washer(s) and allow sufficient thread of the bolt to pass the hex nut.
- For example, a 110mm hex head bolt would suit a 90mm post anchor as shown for Half-Stirrup, Full-Stirrup and Centre-Fix

POST FASTENERS

- Buildex offer a 40 & 50mm Construction Screw designed specifically for fixing Post Anchors.
- The enlarged shank is designed for M10 holes, and the self-drilling point requires no pre-drilling.
- Product Information:
18G x 40mm, 20 pack – X998278
18G x 50mm, 20 pack – X998292

